

PowerEgg

User Manual

PEGF-E1.0

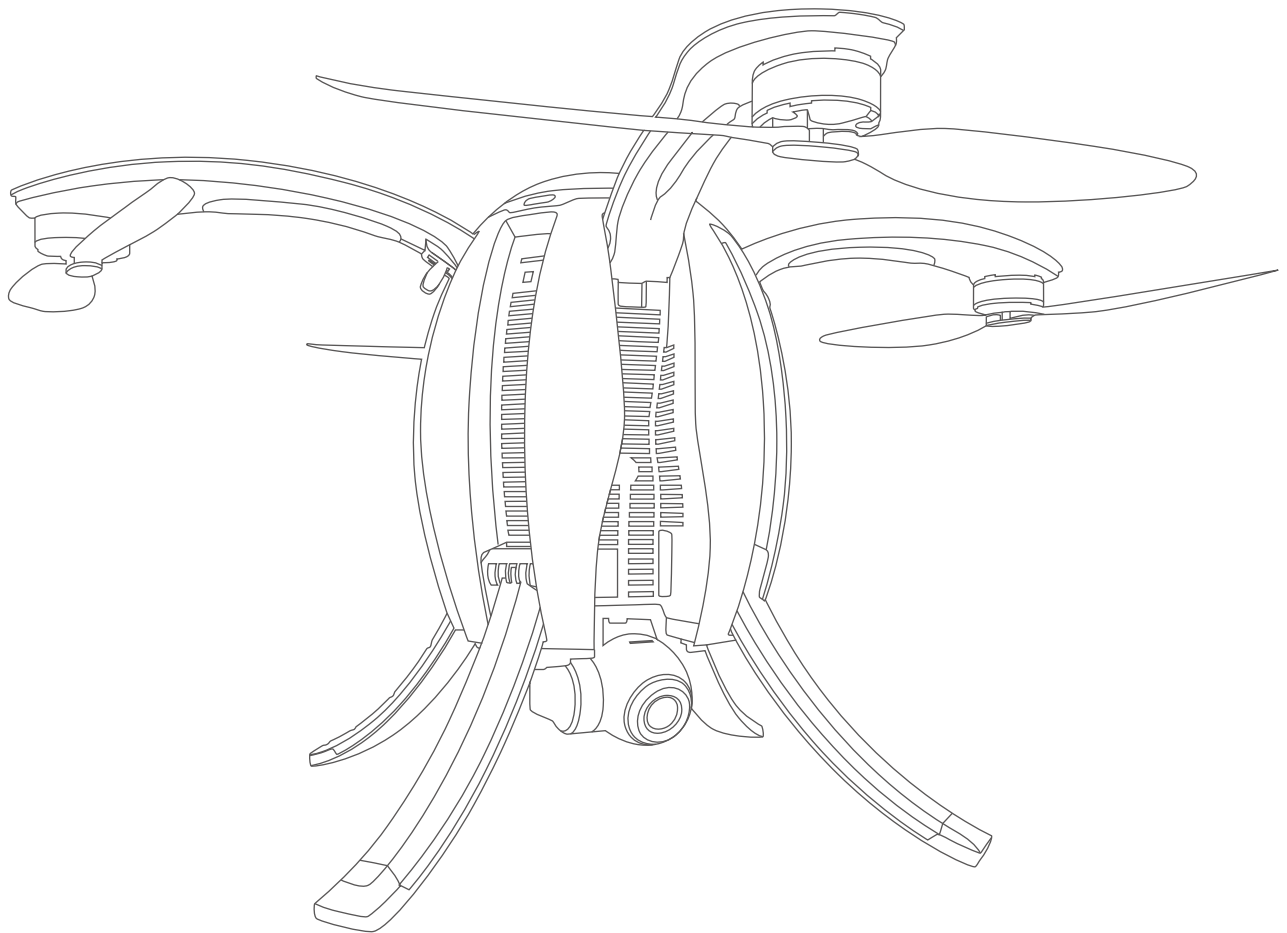

Contents

Product Overview	1
Introduction.....	1
Feature Highlights.....	1
Components of the Aircraft.....	2
Components of Remote Controller.....	3
Preparation of the Aircraft.....	6
Preparation of Remote Controller and Base Station.....	8
Aircraft	9
Overview of the Aircraft.....	9
Flight Modes.....	9
Accessibility.....	10
Aircraft Status Indicator.....	14
Description of Aircraft Status Indicator.....	15
Visual Positioning System.....	16
Propellers.....	18
Intelligent Battery.....	18
Remote Controller	23
Overview of Standard Controller.....	23
Operation of Standard Controller.....	24
Standard Controller Turn On/Off.....	24
Standard Controller Charge.....	25
Standard Controller Control.....	25
Standard Remote Controller Indicator.....	27
Maestro™ Overview.....	28

Maestro™ Operation.....	28
Maestro™ Turn On/Off.....	29
Maestro™ Charge.....	29
Maestro™ Control.....	30
Maestro™ Indicator.....	32
Base Station.....	33
Overview of Base Station.....	33
Operation of Base Station.....	33
Turn On/Off.....	33
Connection.....	33
Frequency Match of Base Station.....	34
Unbind.....	35
Charge.....	36
Indicator	36
Gimbal Camera.....	37
Overview of Gimbal Camera.....	37
Gimbal Usage.....	37
Introduction to Vision+.....	38
Product Description.....	38
Vision+ Features.....	38
Homepage.....	38
Display of Relevant Parameters.....	40
One-click Return Home.....	41
Route Planning.....	41
Flight Modes.....	42
Return Point Settings.....	42
Electronic Fencing.....	43
Positioning.....	43

Layer Switch.....	43
Map Direction Lock.....	43
Image Transmission.....	43
Taking Photos/Shooting.....	44
Settings.....	44
Media.....	47
Service.....	47
Flight.....	48
Flight Restrictions and Special Area Limited Flight.....	48
Flight Environment Requirements.....	49
Connection of Aircraft, Remote Controller and Vision+.....	49
Compass Calibration.....	52
Start/Stop The Motor.....	54
Emergency Stop.....	54
Basic Flight.....	56

Product Overview

Introduction

PowerEgg is a flight system which consists of an aircraft, a gimbal camera, a standard remote controller, a gesture-based remote controller, a base station and Vision+, the flight app for iOS or Android. The user may perform flight over the aircraft by connecting the standard or gesture-based remote controller to the base station. The aircraft integrates a flight system and an integrated 3-axis gimbal to facilitate the user to observe high-definition (HD) images transmitted from the camera in a real-time manner via Vision+ and take photos and video.

Feature Highlights

- 1.Unique egg-shape design and perfect combination of technology and art.
- 2.No dismantling required, integrated design, foldable and easy to carry.
- 3.Operated by an innovative gesture-based remote controller, which enables the user to get started in one minute.
- 4.Flight safety built in.
- 5.360° panoramic shooting with integrated 4K UHD camera + 3-axis self-stabilizing gimbal to guarantee richer scenes.
- 6.Top configuration for 5km* UHD image transmission with 23-minute** flight endurance ability.

*The transmission distance may be shorter depending on local laws and environment.

**It's the maximum time realizable in the testing environment, and it's for reference only.

Aircraft

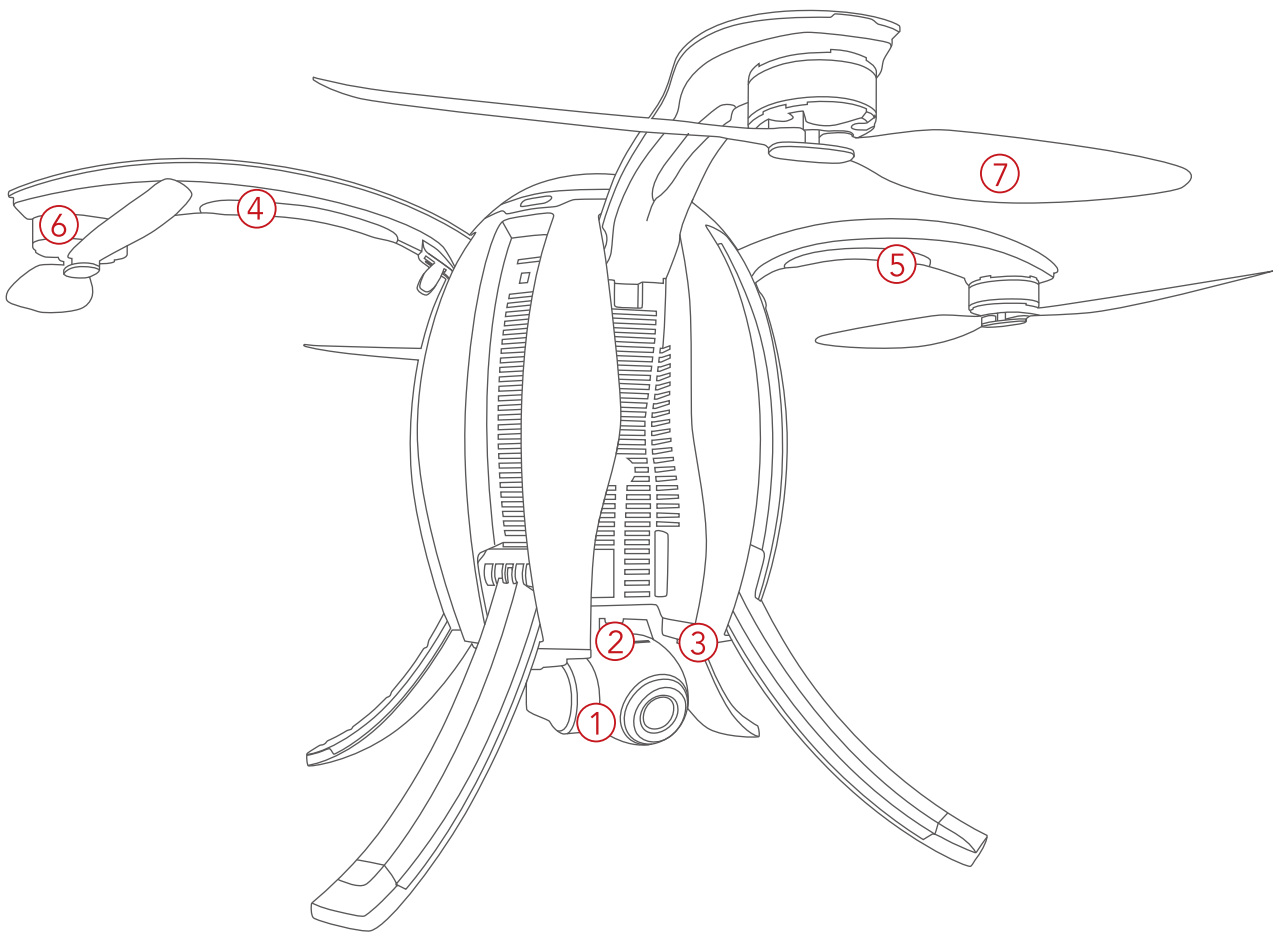

-
- 1.4K UHD camera on 3-axis gimbal
 - 2.Micro SD card slot
 - 3.Optical positioning sensors and ultrasonic positioning system
 - 4.Aircraft front LED indicator
 - 5.Aircraft Status LED indicator
 - 6.Brushless, low friction motor pods
 - 7.Propellers
 - 8.Power switch/Landing gear control/
Frequency button
 - 9.Battery compartment access button
-

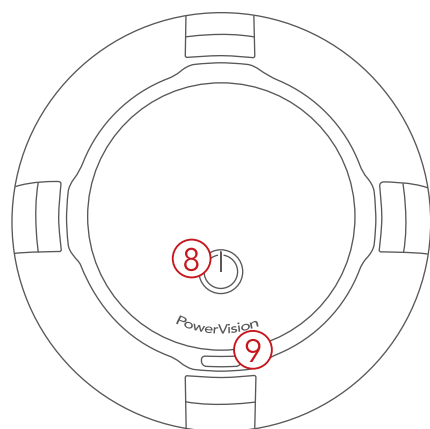

Standard Controller

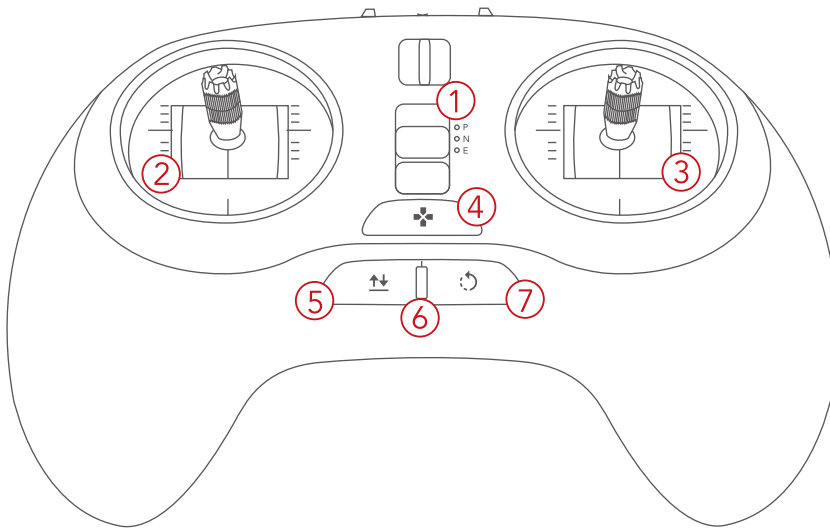

-
- 1. Mode switch
 - 2. Left joystick
 - 3. Right joystick
 - 4. Custom button
 - 5. Take off/land/stop landing
 - 6. Status/battery indicator
 - 7. Return-to-home/Cancel
-

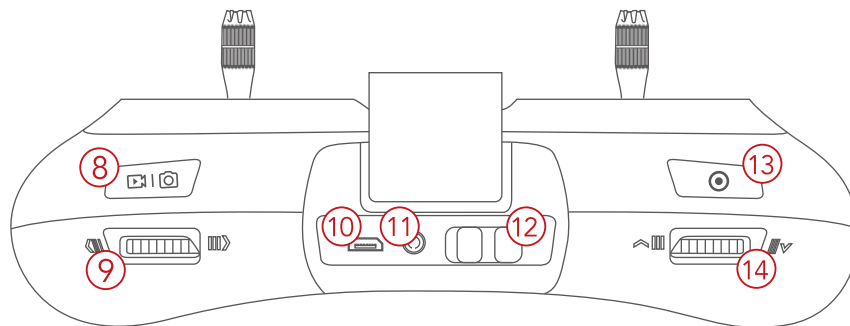

-
- 8. Top right button: take photos/videos
 - 9. Right finger wheel: gimbal yaw
 - 10. Micro USB charging port
 - 11. Port: connect to base station
 - 12. Power Switch

- 13. Left top button: gimbal back to position with short press/selfie with double press/gimbal face downward with long press
 - 14. Left finger wheel: gimbal pitch
-

Maestro™ Gesture-based Controller

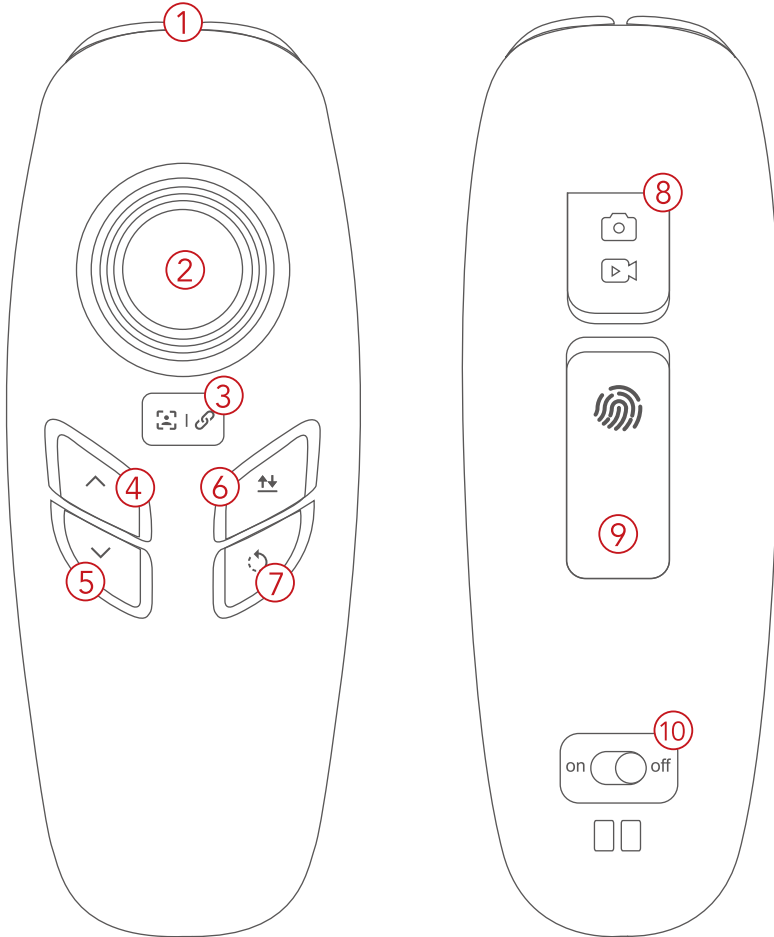

-
1. Status Battery indicator
 2. Joystick: gimbal control
 3. Custom button
 4. Ascend button
 5. Descend button
 6. Take off/land/stop landing
 7. Return-to-home/cancel
 8. Take photos/videos
 9. Gesture activation
 10. Power switch
-

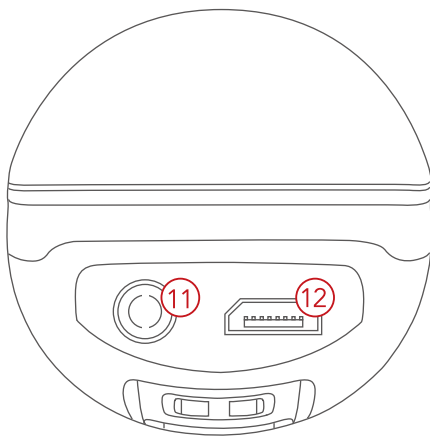

-
11. Port: connect to base station
 12. Micro USB charging port
-

Base Station

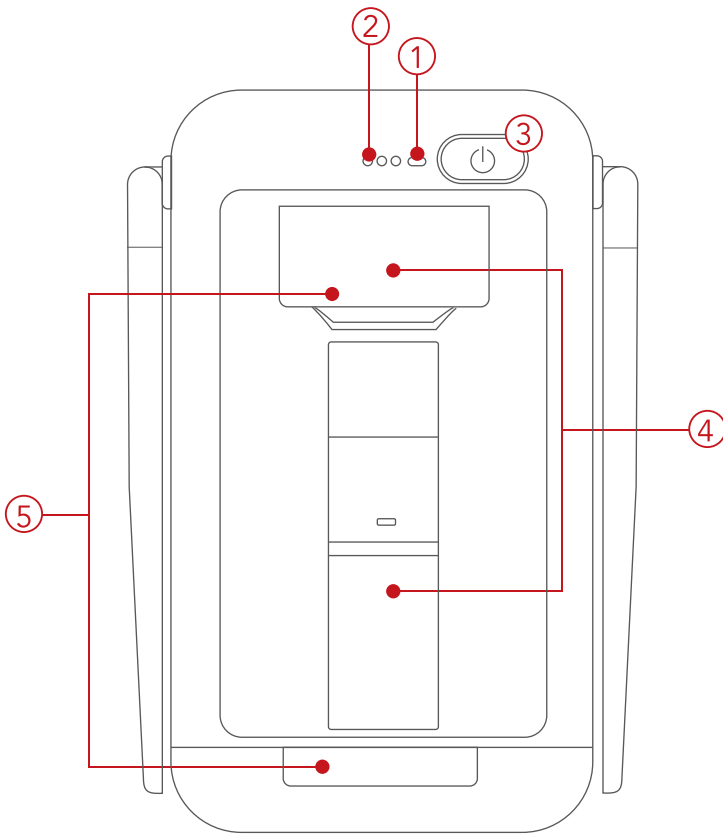

-
- 1. Battery indicator
 - 2. Image transmitting signal indicator
 - 3. Power switch
 - 4. Cell phone connection bracket
 - 5. Tablet connection bracket
-

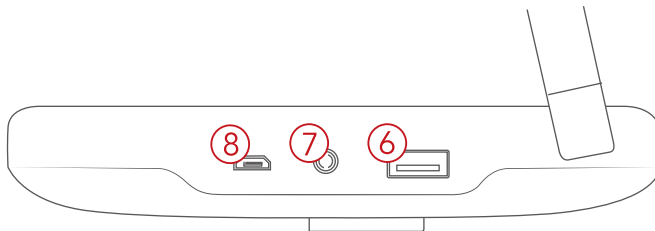

-
- 6. USB port
 - 7. Port: connect to the controller
 - 8. Micro USB charging port
-

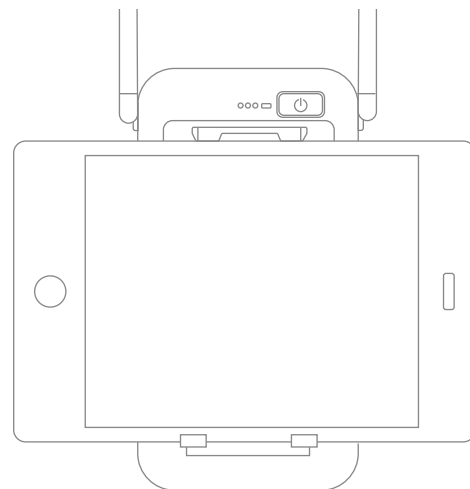
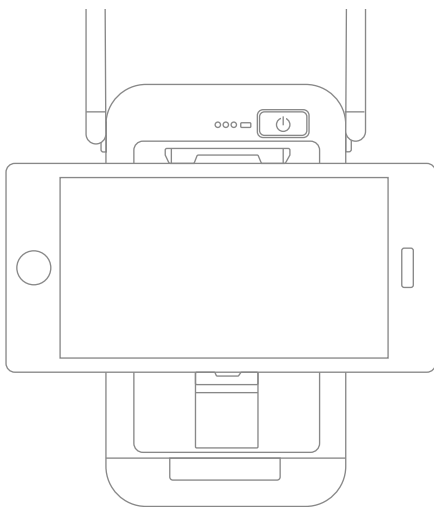

How to use bracket is presented in the graph.

Preparation of the Aircraft

1. Spread the four arms one by one as shown. You'll hear a clicking sound when the arms are properly positioned and self-locked.

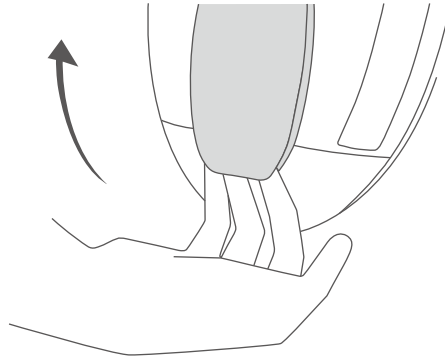

2. Press the upper cover switch and open the top battery cover. Hold the arms and insert the battery into the chamber. You'll hear a clicking sound when the battery fits in the chamber and gets locked. Note: When replacing the battery while the landing gear is deployed, do not insert the battery without first lifting and holding the aircraft. Not doing so may result in your device being damaged.

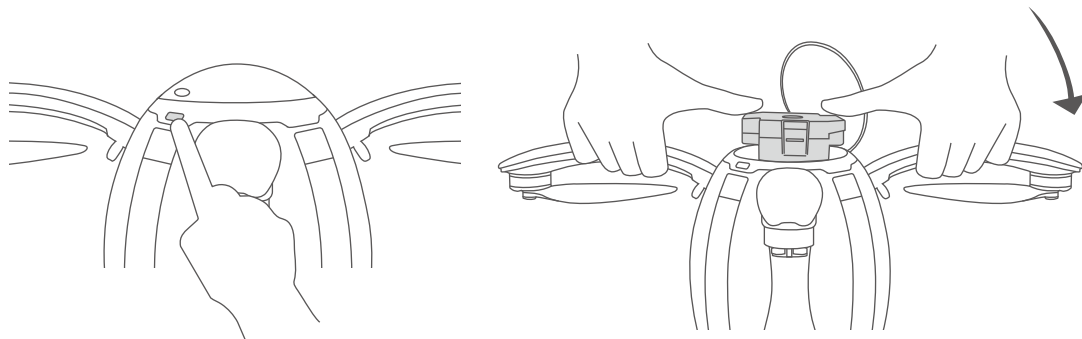

3. Take off the lower cover. Note: The lower cover must be removed before the unit is powered on, otherwise the 4K UHD gimbal camera can become damaged.

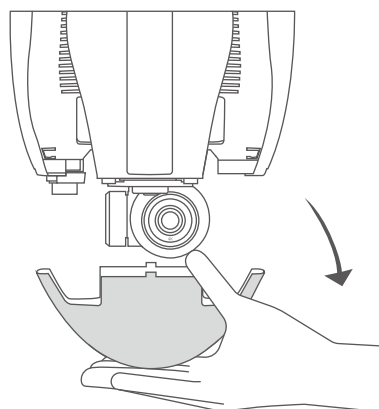

4. First short press and then long press the power button to power on the device. To deploy the landing gear, quickly press the power switch three times when the blue status indicator of the aircraft is on.

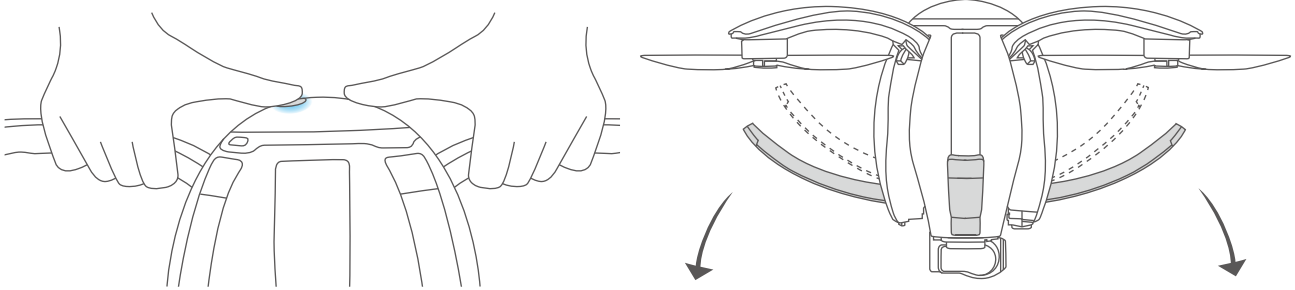

5. Spread the propellers of the aircraft with both hands.

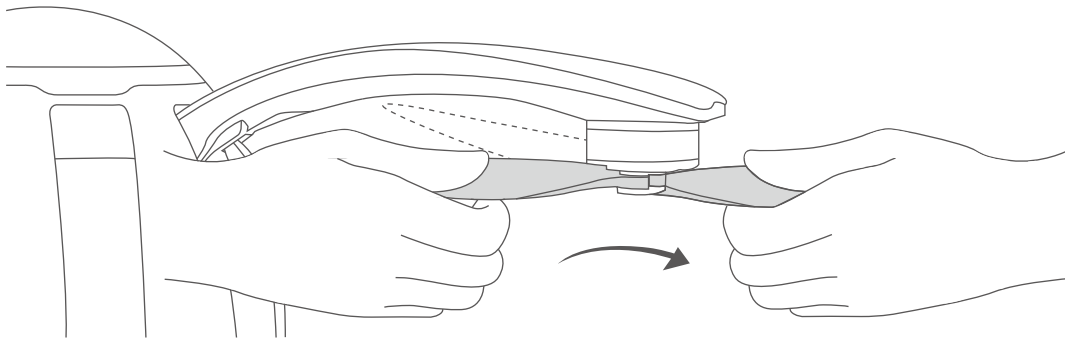

6. Place the aircraft on the ground surface at least 10m from the pilot, with the head of the aircraft (indicated by the red lights on the arms) facing the flying direction and pilot facing the tail (the power button also indicates the front of the aircraft).



Preparation of Remote Controllers

If the gesture-based remote controller is used for flight control, first connect the base station and the gesture-based remote controller with a data cable.

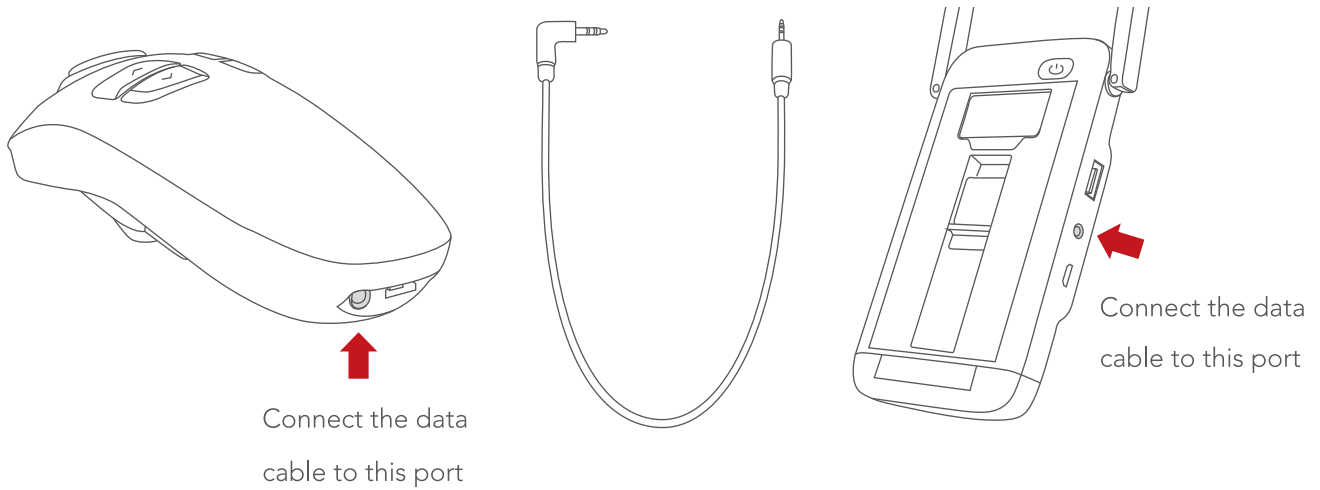

If the standard remote controller is used for flight control, connect the base station to the bracket of the standard remote controller and connect them through cable.

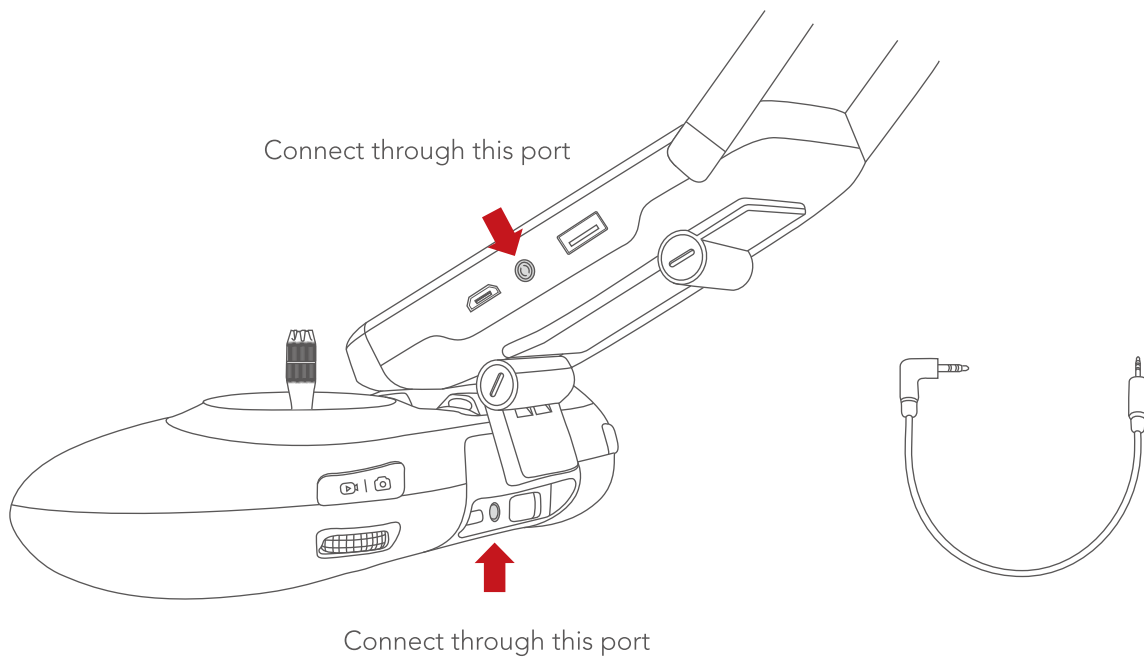

Aircraft

Flight Modes

PowerEgg has three different flight modes:

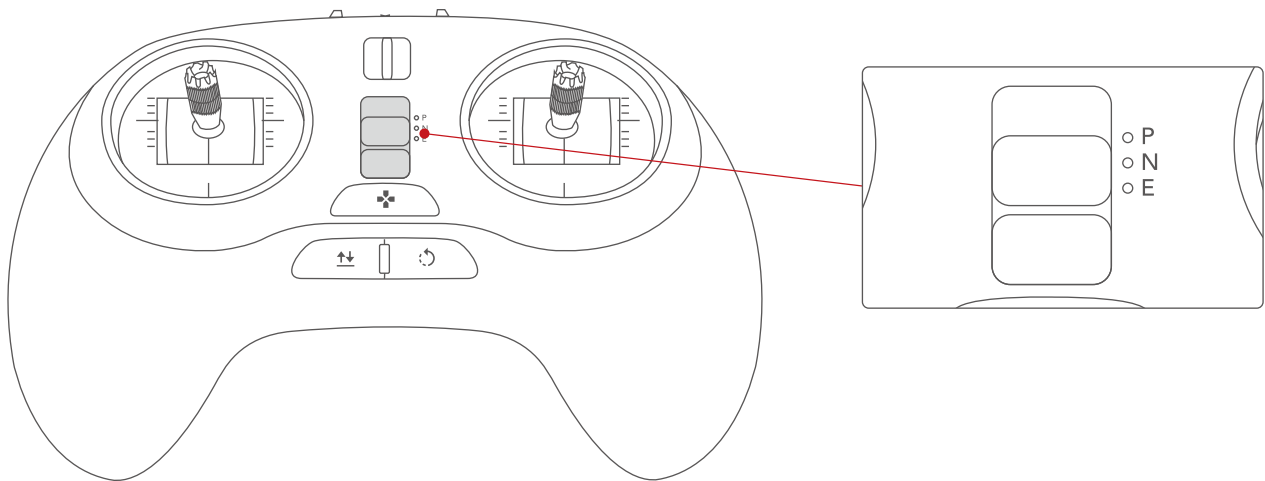

- P Mode (Professional): professional flight mode

In this mode, sonar is used instead of GPS and the visual positioning system. The aircraft is essentially on full manual control.

- N Mode (Normal): Normal flight mode

In this mode, the aircraft uses GPS or the visual positioning system, depending on their signal strength. If GPS is unavailable the visual positioning system and sonar are used to ensure accurate hovering of the aircraft, including indoors. When neither GPS signals nor the visual positioning system satisfies the condition for proper and safe flight, the system will automatically switch to Professional Mode. In this case, only sonar is provided.

- E Mode (Easy Control): Super-easy flight mode

In this mode, the aircraft uses GPS and there is no need to focus on the flight orientation of the aircraft. There is a 10m radius safety zone with the user as the center of the circle, where

the aircraft cannot enter. The forward and backward flight direction of the aircraft is relative to the operator. Pushing the right joystick up will move the aircraft away from the operator, regardless of aircraft orientation.

Accessibility

- Automatic take-off

Unlock the aircraft and ensure flight conditions for either via GPS signals or the visual positioning system meet minimum requirements. Long press the automatic take-off button on the remote controller until it vibrates. The aircraft ascends to a height of 1.3m above the ground at a set speed and then automatically hovers in the air.

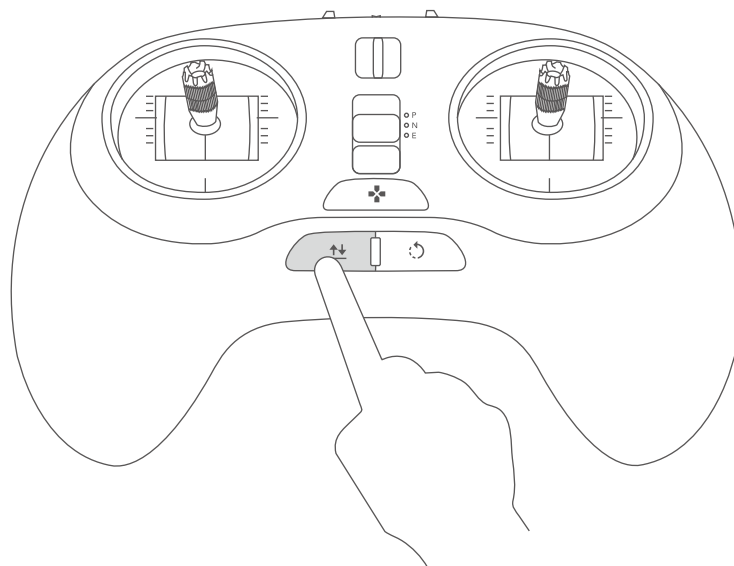

- Automatic landing

Long press the automatic landing button until it vibrates. The aircraft starts to descend at a set-speed from the current position, subject to horizontal control during descending.

- Smart return-to-home

The smart return-to-home mode may be applied only when there is ample GPS signal. In this mode, the aircraft returns to the return point from the current position (when switched to the return-to-home mode).

Smart return-to-home behavior

The return-to-home behavior depends on the location of the aircraft when it is switched to return-to-home mode.

1. When the aircraft is located within 10m horizontally from the return-to-home point, it deploys the landing gear and automatically lands on the spot.

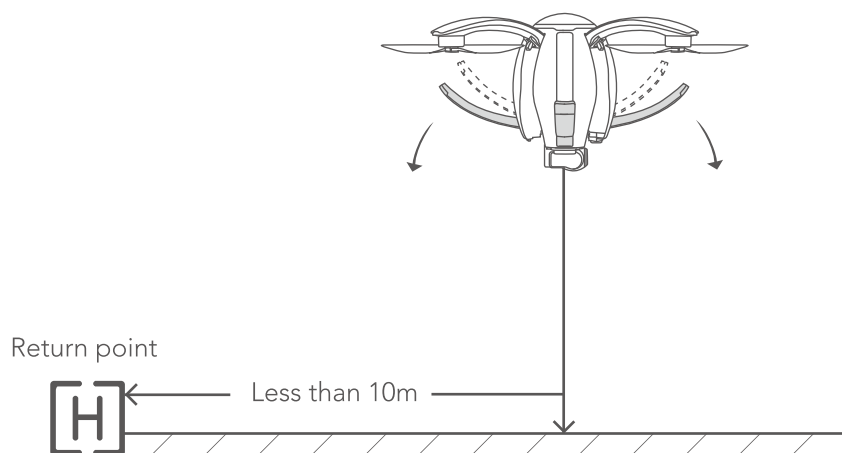

2. If the aircraft flies higher than the return altitude (default value: 20m) beyond 2.10m, it first makes a turn to face its head towards the operator, flies to the position above the return point, and then deploys the landing gear for vertical landing. The location of final landing can be controlled by the joystick.

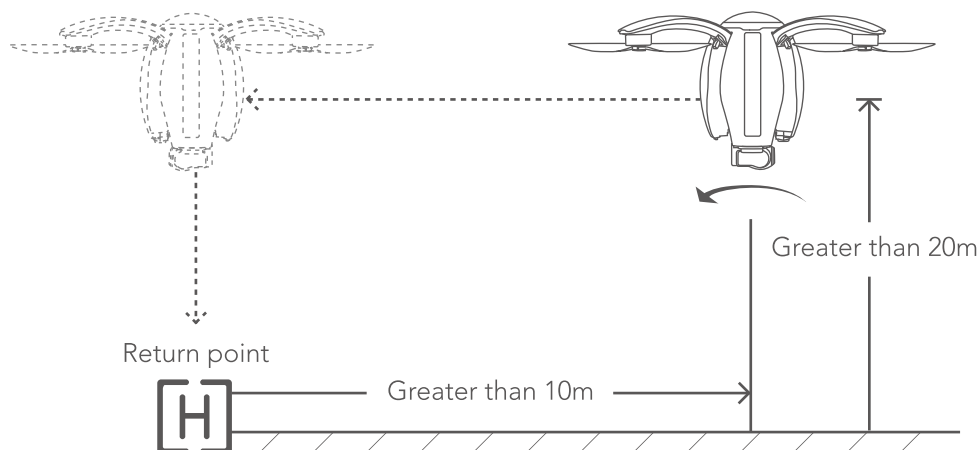

If the aircraft flies lower than the return altitude beyond 3.10m, it first vertically climbs to the return altitude, then turns the head to the operator and returns to the point above the return point. Then, the aircraft turns the tail towards the operator, deploys the landing gear and vertically lands on the ground. During the final descent, the location of final landing can be controlled by the joystick of the remote controller.

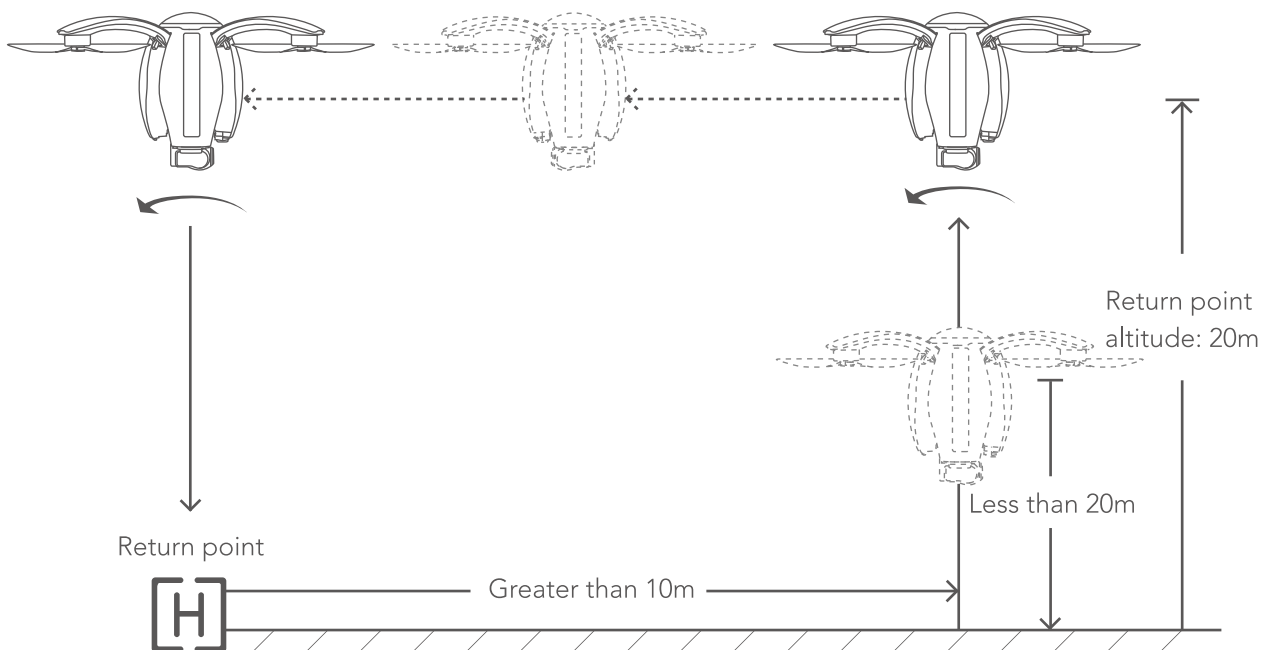

Return point

There are three kinds of return points: user location, aircraft starting point and map selection point. The take-off point of the aircraft will be selected as the return point for default when changed in the Vision+ app. Each time after power cycling the aircraft, the return point will be automatically reset to the take-off point. Please select a proper return point each time after power cycling.



User location



Aircraft starting point



Map selection point

Categorization of smart return-to-home

Smart return-to-home can be realized in three patterns: lost control return, one-click return and low power return

1. Lost control return

In the case of loss of signal, the aircraft first hovers in the air and then triggers lost control return in 10 seconds. After gaining signal of the remote controller again, the aircraft switches to the mode used prior to the loss of signal and continues to fly.

2. One-click return

Long press the return-to-home button on the standard remote controller to trigger one-click return. Short press the button to cancel return-to-home. The aircraft can operate at different horizontal positions via the joystick of the remote controller during the descending process.

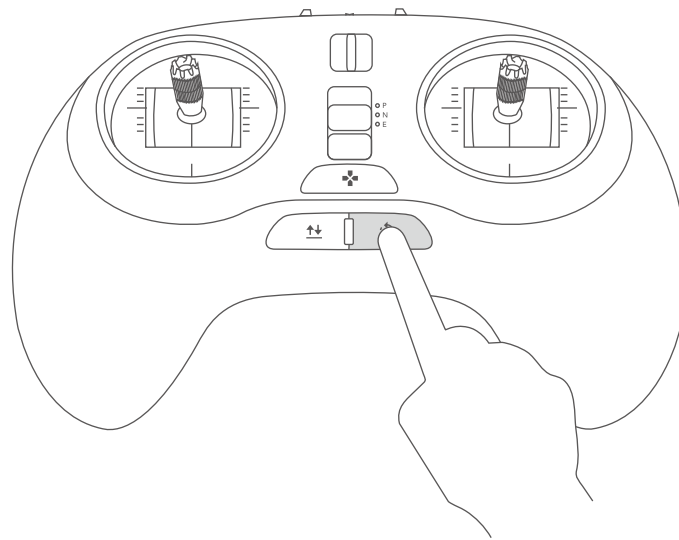

3. Low-battery return

When battery level of the aircraft drops to a predetermined level, Vision+ will pop up a message for the user to decide whether to trigger low-battery return. Click "Yes" to return the aircraft. Return can be terminated by pressing the automatic Return-to-home key on the standard remote controller. During the descending process, the user may manipulate the joystick to change the position of the aircraft in horizontal direction so that it can land in a safe zone.

Note: The aircraft may have obstacles in its path during return-to-home. The user needs to detect such obstacles via visual observation or image transmission, and avoid these obstacles by means of ending the return-to-home process or adjusting flight height of the aircraft.

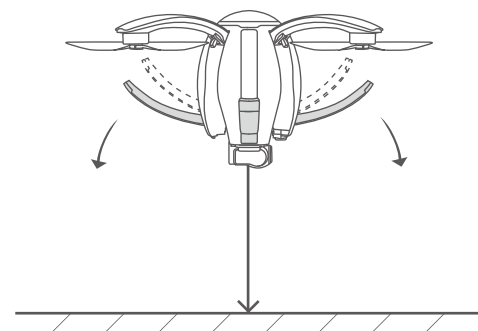
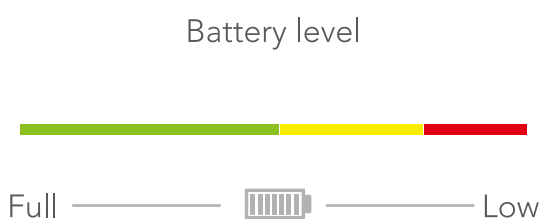

- Orbit mode

While flying with GPS, the aircraft flies at a height of 10m above the ground. Specify the center of a circle via Vision+ and manipulate the aircraft to fly to any position 10m beyond the center of the circle. Set the orientation via Vision+ and start the circling mode. During circling, the head of the aircraft will always point at the center of the circle.

- Selfie mode

While flying with GPS, the user only needs to press the Selfie button on the gesture-based remote controller when the aircraft is flying. The head of the aircraft will automatically aim at the user.

- Waypoint mode

While flying with GPS, the user may set a flight waypoint via Vision+ and the aircraft will fly on the set waypoint trajectory.

- Follow-me mode

While flying with GPS, the aircraft can follow the standard or gesture-based remote controller and move correspondingly at a certain distance, with the flight height adjusted by the remote controller.

■ Aircraft Status Indicator

Each arm of PowerEgg has a head indicator (head lamp) and an aircraft status indicator (tail lamp). The following figure indicates the specific locations of the indicators.

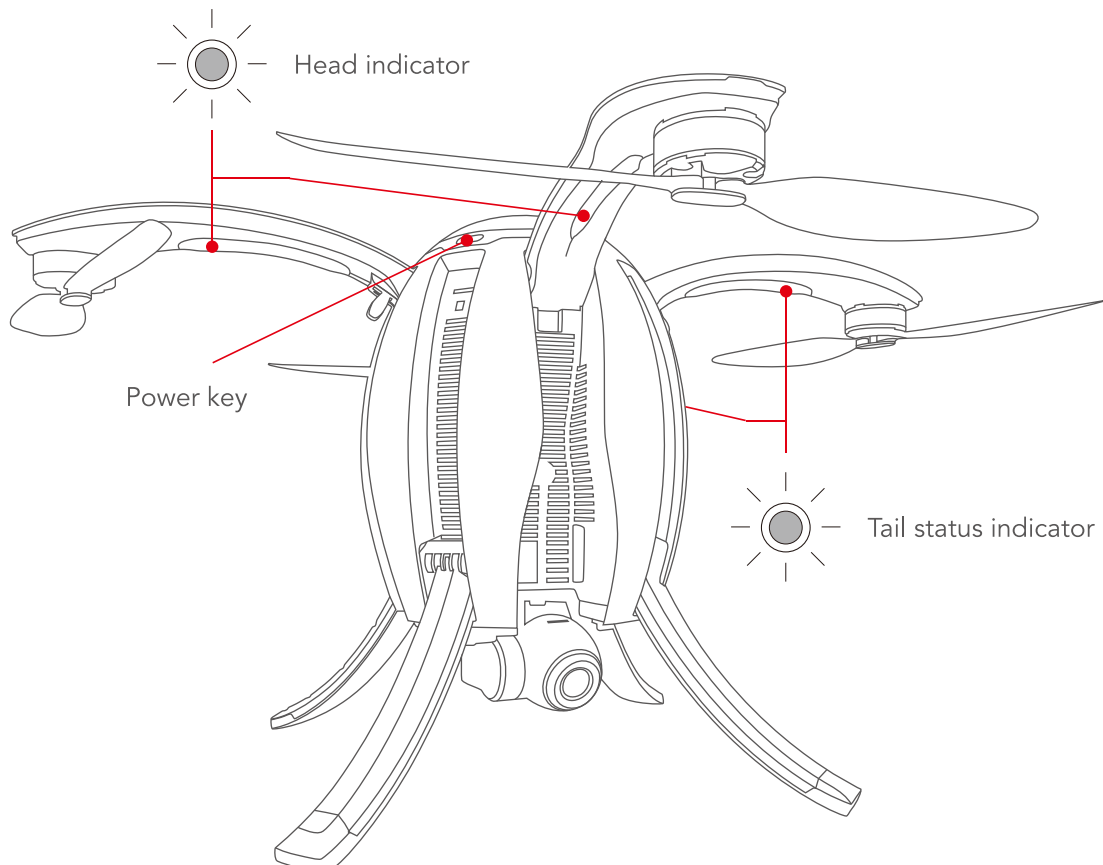

The head indicator is used to identify the head direction. When the power of the aircraft is turned on, the indicator is normally on and lights in red. The tail indicator gives information about status of the aircraft, with different flashing modes indicating different statuses.

Description of Aircraft Status Indicator

The head indicator is red when the aircraft is powered and the system is operating normally.

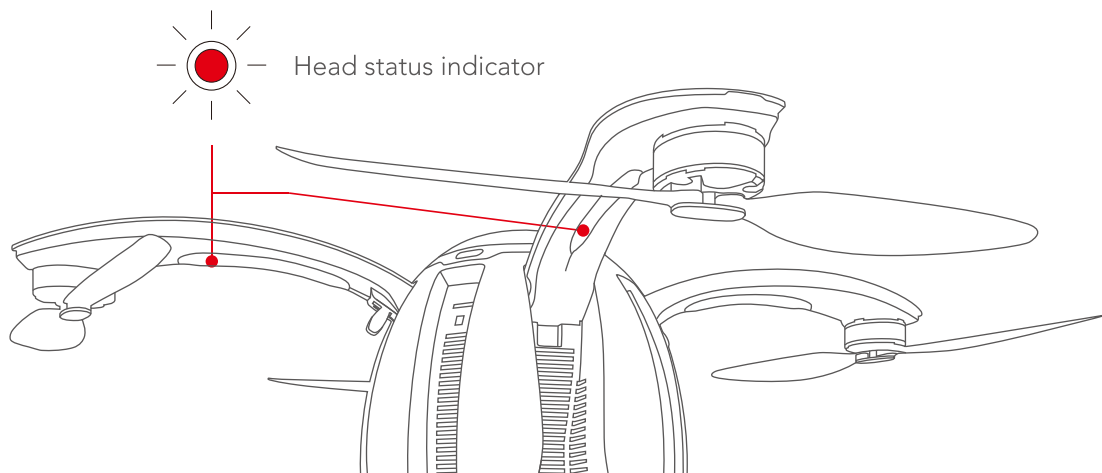

The tail indicator LEDs provide status information on the aircraft back to the operator:

S/N	Description	Flashing process of Status Indicator
1	Systems check during power-on: successful system check	Alternative flashing in red, green and blue once
2	Failed system check	Slow flashing in red
3	GPS signal acquired or optical flow is functioning	Slow flashing in green
4	No sufficient GPS signal or optical flow is not functioning	Slow flashing in yellow
5	P Mode (Professional) after motor startup	On in yellow
6	N Mode (Normal) and other accessibility mode	On in green
7	E Mode (Easy Control)	On in white
8	Trigger landing gear deploy/withdraw	Quick flashing in yellow

9	Shutdown process	Quick flashing in white
10	Code matching of remote controller	Slow flashing in blue
11	Alarm of low battery or loss of signal of remote controller	Slow flashing in red
12	Successful mode switching; successful task execution; successful sensor calibration	Flashing in green
13	In a no-fly zone where take-off is forbidden	Slow flashing in red

Visual-aided Positioning System

The visual-aided positioning system is ultrasonic and camera based, with the camera obtaining the current position of the aircraft and ultrasonic wave used to measure the altitude so as to achieve accurate hovering and positioning of the aircraft. The visual-aided positioning system is located at the bottom of the aircraft, as shown in the figure below, and consists of two modules: ultrasonic and optical flow.

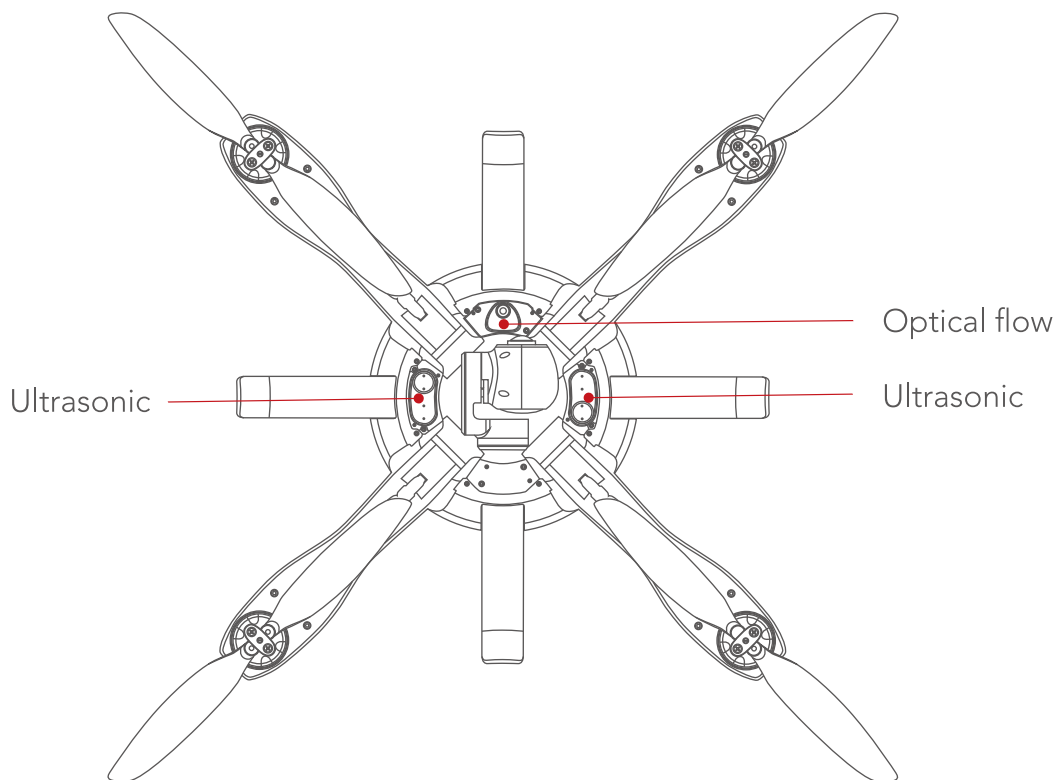

- Optical flow positioning system

The optical flow positioning system applies to any environment having a height not greater than 3m and with weak or no GPS signals, particularly for indoor flight. See the figure below.

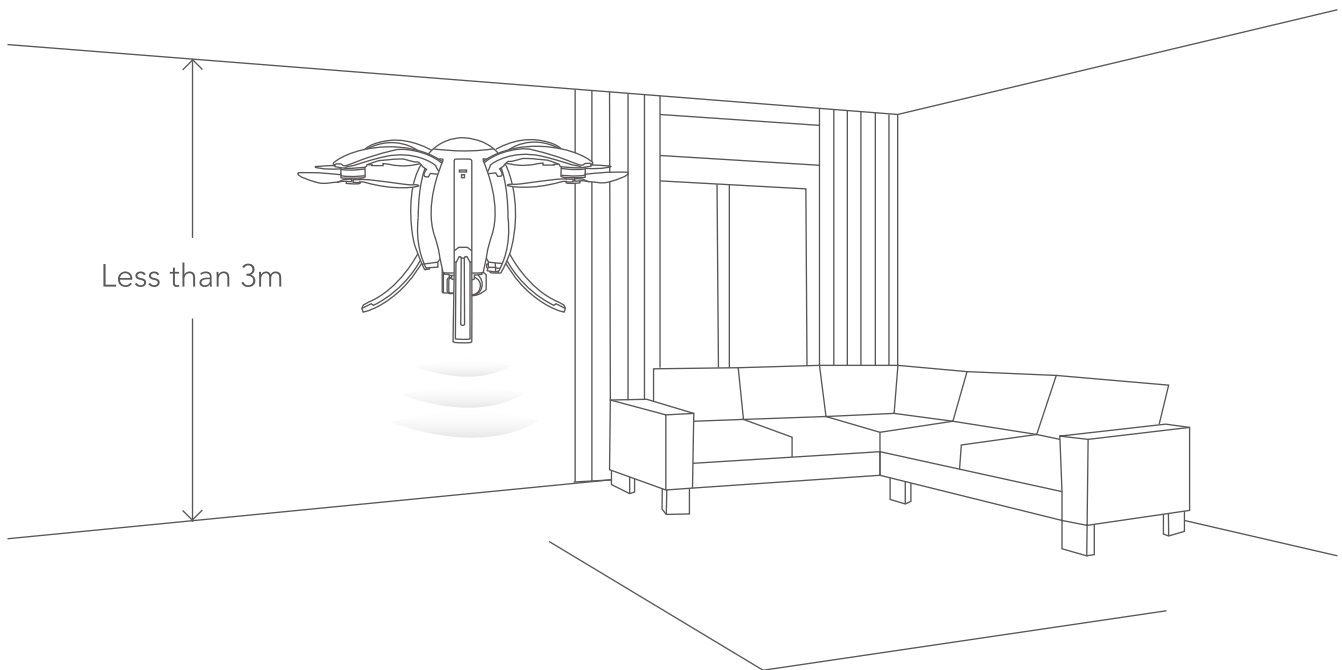

- Using steps of the optical flow positioning system

1. Switch the remote controller to N Mode: normal flight mode.
2. Turn on the power. The aircraft status indicator will be green.
3. The aircraft takes off. The optical flow positioning system will hold the aircraft in position.

- Scenarios that may contribute to failure of the optical flow positioning system

1. When the aircraft takes a low-altitude flight (below 0.5m) at a rapid speed, the optical flow positioning system may fail to locate the aircraft.
2. Solid color plane.
3. A strongly reflective, reflective, water or transparent surface (such as glass floor, ice surface and lake surface).
4. Flying with excessive speed (exceeding 3m/s at 1m above the ground or 6m/s at 2m above the ground).
5. Surface of a moving object (over grass, crops and bushes blown by wind or over a crowd).
6. An extremely dark (the range) or bright (range) environment.
7. A surface that is highly absorptive to ultrasonic waves (e.g. thick carpet and elastic cotton).
8. A surface with sparse texture.

9. A surface with highly repeated textures (e.g. black and white lattice tiles).
10. Any slopes steeper than 30° can impede the receiving of ultrasonic waves.

- Precautions

1. Ensure the lens of the optical flow positioning system is clean before flight.
2. The optical flow positioning system only operates up to an altitude of 3m.
3. The optical flow positioning system obtains information depending on ground surface images. Please ensure that surrounding environment is well lit and the ground texture is rich.
4. The optical flow positioning system cannot function normally on water, in a dark environment, or where there is no clear ground texture.
5. The ultrasonic waves emitted from the optical flow positioning system can upset animals. Ensure no animals are in the proximity when the system is in operation.

■ Propellers

PowerEgg uses customized high-performance 10.5-inch folding propellers.

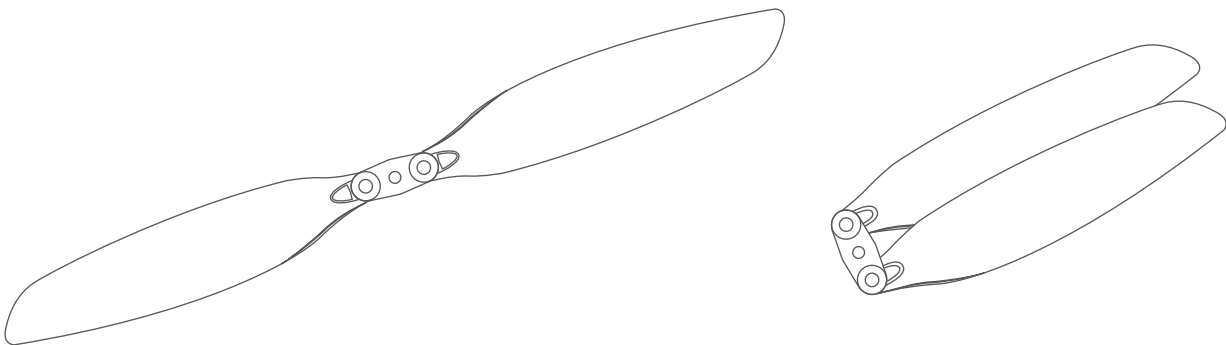

■ Intelligent Battery

PowerEgg is equipped with a specially designed smart flight battery which has a capacity of 6,400 mAh, operates at a voltage of 14.8V and has charging-discharging management capabilities. The battery consists of high-energy cells and an advanced battery management system to guarantee adequate power supply to the aircraft. The intelligent battery must be charged using the special charger supplied by PowerVision.

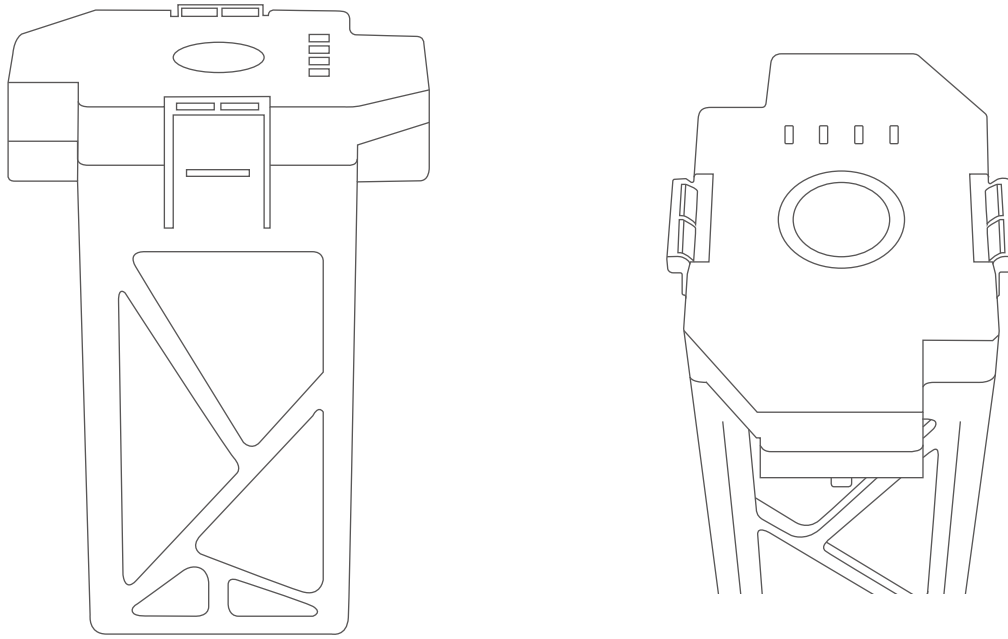

! Make sure the intelligent battery is fully charged before its first use. Please refer to "Battery charging" for details.

- Functions of the intelligent battery

The intelligent battery has the following functions:

1. Battery status display: the battery has a status indicator to indicate current status of the battery.
2. Battery life display: the battery has a status indicator to indicate life of the battery.
3. Self-discharging protection for battery storage: if the battery is stored for 10 days without any operation when its battery level is higher than 65%, it can trigger the self-discharging function to lower the battery level to 65% for the protection of the battery. The self-discharging process may last for about two days with no LED indication. The battery may heat up slightly, which is normal.
4. Balance charging protection: cell voltage of the battery can be automatically balanced to protect the battery.
5. Overcharging protection: Charging will be automatically stopped when the battery is full.
6. Charging temperature protection: the battery will be damaged if it is charged at a temperature lower than 0°C or higher than 40°C. This function is to ensure the battery will not be charged at such temperatures.
7. Overcurrent protection during charging: heavy current charging can severely damage the battery. Charging will be stopped if the current exceeds 8A.
8. Over-discharging protection: over-discharging can severely damage the battery. The battery output will be cut off if it is discharged to 12V.
9. Short-circuit protection: the output will be cut off to protect the battery if short-circuit is detected.

10. Cell damage detection: a warning for battery damage will be sent out if cell damage or significant cell imbalance is detected.

11. Records of use exceptions of the battery: the app can provide the records of the last 31 times of use exceptions of the battery, including battery short-circuit, excessive discharging current, etc.

12. Sleep protection: the battery will enter into sleep if it is not connected to any electrical equipment 20 minutes after it is turned on.

13. Communication: the aircraft can acquire real-time information of the battery through the communication interface on the battery, including voltage, battery level and current.

 Please carefully read and abide by the requirements of PowerEgg provided in this manual, the disclaimer and the tag on the battery before use. The user shall assume the consequences for not using the battery as instructed.

● Battery Usage

Installation: The battery is installed with wrong plug-in protection design, so there is no need to worry about which way to plug in.

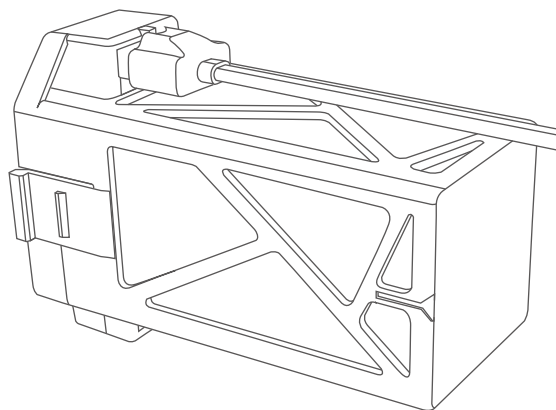

Turn-on: insert the battery into the aircraft. Short press once and then long press once in the shutdown mode. Turn on the battery to supply power to the aircraft.

Turn-off: Short press once and long press the power button of the aircraft once to turn off the battery.

Battery level checking: touch the key switch (less than 2s and then release it). The LED indicator will indicate the battery level.

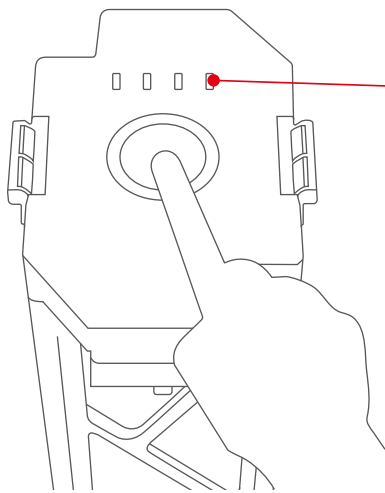

Battery level indicator ● Each indicator represents about 25% of total battery level.

Lightly touch the key on the top of the battery to light the four white indicators. The number of indicators indicates the charge level.

The battery of the aircraft must be charged using the special charger supplied by PowerVision. PowerVision takes no responsibility for the consequences of using any other chargers.

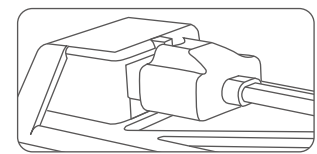
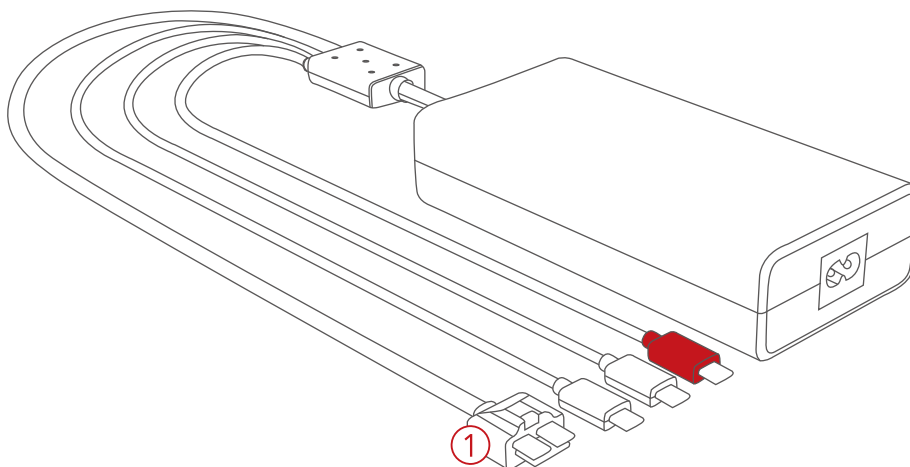

① Battery

2.5 hours for full charging

- Precautions for use at low temperatures

1.The use of the battery at low temperatures (-10°C to 5°C) will lead to abrupt reduction in battery capacity and thus significant reduction in flight duration of the aircraft. When battery temperature is between -10°C and 5°C, the aircraft cannot take off unless a certain voltage is satisfied. Please fully charge the battery and take thermal insulation measures for the battery before use.

2.It's not recommended to use the battery at ambient temperature lower than -10°C.

3.It is suggested to end the flight when a low-voltage warning is sent from the PowerEgg Ground Station in a cold environment.

4.It is suggested that the battery be preheated to over 5°C at the minimum, or over 20°C ideally, before the aircraft takes off in a cold environment.

- Battery charging

1. Connect the charger to an AC power source (100-240V, 50/60HZ; use a power converter if necessary).
2. Connect the battery to the charger, with the battery turned on or off.
3. During charging, the battery status indicator will keep flashing and indicate current battery level.
4. The battery is fully charged when all indicators go off. After charging, please remove the battery from the charger.
5. The battery will be warm after a flight, and should not be charged until it is cooled down to ambient temperature.
6. The optimal temperature range for charging is 0°C to 40°C. Charging will be denied by the battery management system if cell temperature is not within this range.



Use a standard charger to charge one piece of equipment each time. Ensure the battery is turned off before it is installed into or removed from the aircraft. Do not insert or remove the battery when it is turned on.

The smart battery must be charged using the special charger supplied by PowerVision. PowerVision will take no responsibility for the consequences of not using the chargers provided by PowerVision.

- Precautions for traveling with PowerVision

1. Ensure that the battery is discharged to a level below 5% before carrying it onto a plane. Keep the battery away from heat sources before discharging. Ensure the battery is separated from the aircraft.
2. Keep the battery separate and away from any metal object.
3. Retract the landing gear and fold the arms back to the main body. Install the gimbal cover to fix the 4K UHD camera.
4. Place the aircraft in a packing bag.

Remote Controller

I Overview

This section describes the functions of the remote controllers as well as the way of controlling the flight of the aircraft and taking photos with the camera. Two types of remote controllers are available for PowerEgg: standard controller and gesture-based “Maestro”. The gesture-based remote controller requires GPS positioning and thus cannot be used for flights indoors or in other environments with weak or no GPS signals.

I Overview of Standard Remote Controller

PowerEgg standard remote controller integrates one-click takeoff and landing, one-click return-to-home, open and close of the landing gear, control of gimbal pitch and control of gimbal yaw, one-click back to position and one-click facing downward, taking photos and video shooting with the 3-axis gimbal. The built-in rechargeable battery in PowerEgg standard remote controller has a capacity of 3,000mAh and can continuously work for 20 hours. The current battery level may be checked via the battery level indicator.

The standard remote controller has a built-in GPS receiver. Easy Control mode is available to the aircraft and the remote controller only when the GPS signal is good, otherwise the aircraft cannot be started.

When the GPS signal of the aircraft and the signal of positioning or visual aids system is good (the green indicator flashes slowly), the aircraft may fly in Normal mode.

Compliance version: PowerEgg remote controller complies with both CE standards and FCC standards.

Mode of remote control: The remote controller has Mode 1 and Mode 2, and may be self-defined in Egg Vision+. Beginners are suggested to operate in Mode 2.

Mode 2: The joystick for the control of up/down is the left joystick of the remote controller.

Mode 1: The joystick for the control of up/down is the right joystick of the remote controller.

Operation of Standard Remote Controller

- Startup and shutdown of standard remote controller

The remote controller may be started by sliding the power switch from the left to the right. The connection status of the remote controller may be distinguished according to the notification tone of the remote controller. When the remote controller plays music for 1 second, it indicates that the communication connection between the remote controller and the aircraft is successful. Slide the power switch from right to left to shut down the remote controller.

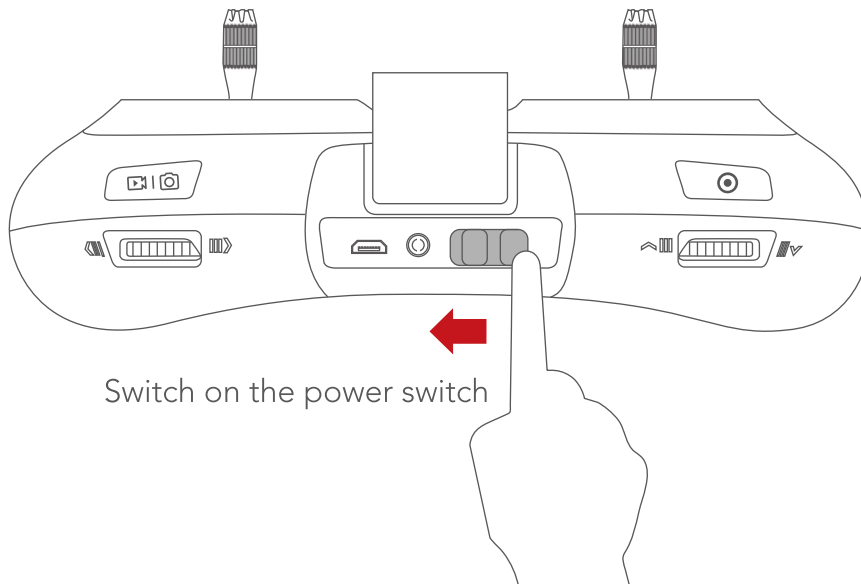

- Charging of standard remote controller

1. Connect the charger to AC power supply (100-240V, 50/60HZ; use a power conversion plug when necessary)
2. Connect the battery to the charger, with the battery turned on or off.
3. During charging, when the standard remote controller is shut down, the battery level indicator will turn red and then turn green when it is fully charged.
4. During charging when the standard remote controller is on, the battery level indicator will show the battery level of the lithium battery:

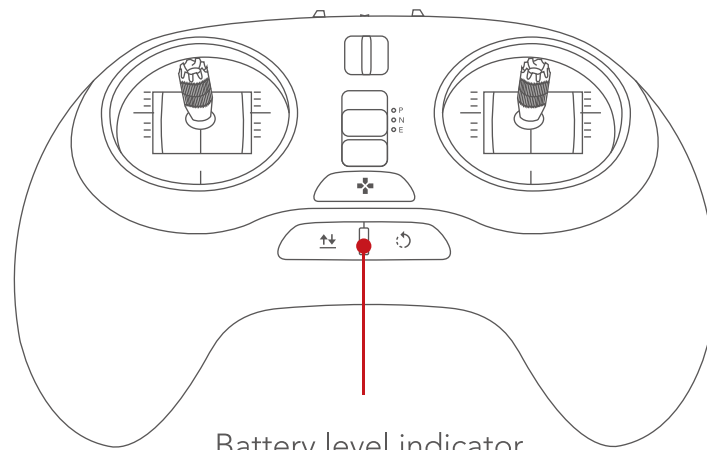

Battery level indicator



More than 30%

10%-30%

Less than 10%

The battery of the remote controller should be charged with the special charger officially designated by PowerVision, which will not be liable for any consequences caused by charging the battery with the charger not officially provided by PowerVision.

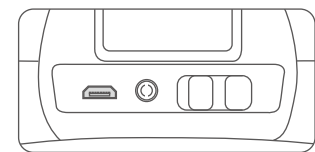
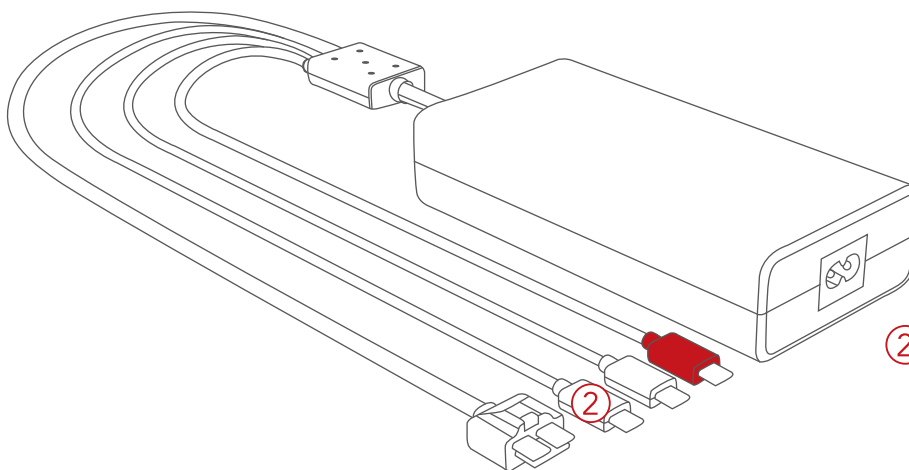

② Standard Remote Controller

3.5 hours for full charging

- Control of standard remote controller

Left joystick: Up and down control the upward and downward movement of the aircraft; left and right control the horizontal rotation of the aircraft.

Right joystick: Up and down control the forward and backward movement of the aircraft; left and right control the left and right movement of the aircraft.

Mode 2: The left joystick of the remote controller controls the up/down of the aircraft.

Mode 1: The right joystick of the remote controller controls the up/down of the aircraft.

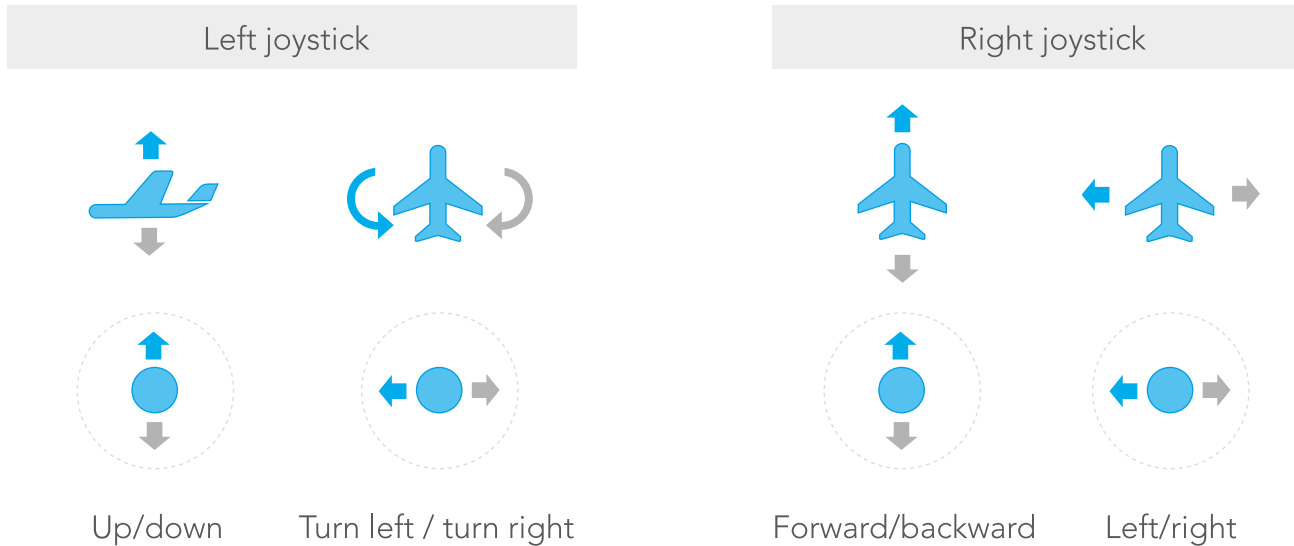

Start of motors: Position both joysticks towards the bottom center like a "V" to unlock within 2 seconds, i.e. the left joystick towards lower right corner and right joystick towards lower left corner.

Emergency locking: In case of emergency, press the combination keys, i.e. the ascend/descend joystick at the lowest + heading at the most left + return-to-home button locking propeller, for 2 seconds for emergency shutdown. This may be used in case of emergency. The aircraft will drop vertically due to loss of power. Under normal circumstances, the motor may be automatically stopped when the aircraft lands.

One-click takeoff/landing button: When the aircraft has not taken off, press and hold the key until there is a vibration, and the aircraft begins to take off; when the aircraft takes off, press the key again until there is another vibration, and the aircraft begins to land; short press the key in the process of landing, the aircraft stops landing.

One-click return-to-home: When the aircraft is not in return-to-home status, press the key until there is a vibration, and the aircraft begins to return-to-home; when the aircraft is in return-to-home status, short press the key until there is another vibration, and the aircraft stops return-to-home.

Custom button: It is for landing gear control by default. Press the key until there is a vibration, and the landing gear is taken back; short press the key, and the landing gear is spread out.

Left finger wheel:for the control of the gimbal pitch.

Right finger wheel:for the control of gimbal yaw.

Left top button:The gimbal back to position by short pressing the key; press the key until there is a vibration, and the gimbal faces downward; short press the key for 2 times, selfie mode is triggered.

Right top button: Short press the key to take a photo; when it is not shooting video, press the key until there is a vibration, and camera shooting starts; during video shooting, press the key until there is a vibration, and video shooting stops.

Flight mode switcher: P/N/E; P: Professional (manual); N: standard (Normal); E: Easy Control (the direction away from the remote controller is the front of the aircraft).

- Indicator for standard remote controller

Standard remote controller has a three-color battery level indicator. The indicator shows the battery level of the battery when the remote controller is on (whether charging or not): In case of charging when the remote controller is off, the indicator is red, indicating charging; when the remote controller is fully charged, the indicator is green, indicating full charging; in case of emergency alarm during flight, the battery level indicator flashes four times each second in the current color.

- Alarm

Type of Alarm Prompt	Button Backlight	Color of Three-Color Light	Buzzer
Aircraft takeoff/landing prompt	The backlight of takeoff/landing key is normally on	No action	No action
Aircraft return-to-home prompt	The backlight of return-to-home key is normally on	No action	Dripping sound, 1 cycle for buzz per second
Low power alarm	No action	The red light is normally on	Dripping sound, 4 cycles for buzz per second
Not positioned by GPS	No action	1 cycle per second in the color of current battery level	No action

The aircraft not connected	No action	Cyclic switching of red, green and blue, 3 cycles per second	No action
Change of GPS positioning state	No action	No action	Tick
State change of connection with the aircraft	Inaction	Inaction	Connected, Do-Re-Mi-Fa disconnection, Fa-Mi-Re-Do

- Compliance version of standard remote controller

PowerEgg remote controller complies with both CE standards and FCC standards.

Overview of Gesture-based Remote Controller

PowerEgg gesture-based remote controller can control the altitude, forward, backward, left and right flight of the aircraft; the gesture-based remote controller integrates one-click takeoff/landing, one-click return-to-home, one-click following/one-click selfie, control of 3-axis gimbal pitch, taking photos and video shooting. Users can easily complete various operations of the aircraft with the assistance of the remote controller.

The built-in rechargeable battery in PowerEgg gesture-based remote controller has a capacity of 1,500mAh and can continuously work for 10 hours. The current battery level may be checked via the battery level indicator.

The standard remote controller has a built-in GPS receiver, which is available only when the GPS signal of the aircraft and the remote controller is good. The gesture-based remote controller and the aircraft are unavailable where the GPS signal is poor or there is no GPS signal (such as indoor, urban agglomeration and accessory of high structures).

Compliance version: PowerEgg remote controller complies with both CE standards and FCC standards.

Operation of Gesture-based Remote Controller

- Start-up and shutdown of gesture-based remote controller

The remote controller may be started by sliding the power switch from the left to the right. The connection status of the remote controller may be distinguished according to the notification tone of the remote controller. When the remote controller plays music for 1 second, it indicates that the communication connection between the remote controller and the aircraft is successful. Slide the power switch from right to left to shut down the remote controller.

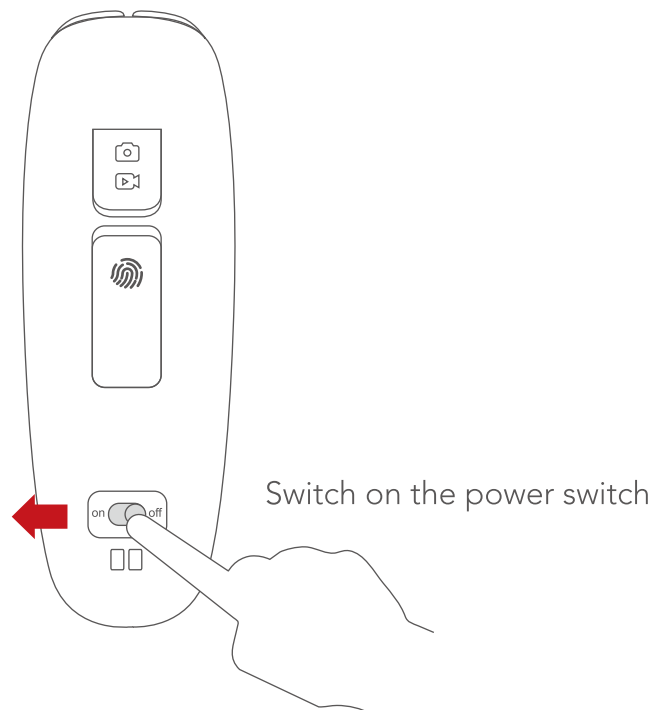

- Charging of gesture-based remote controller

1. Connect the charger to an AC power source (100-240V, 50/60HZ; use a power converter if necessary);
2. Connect the battery and the charger when the battery is on or off;
3. During charging, when the standard remote controller is shut down, the battery level indicator will turn red and then turn green when it is fully charged;
4. During charging, when the standard remote controller is on, the battery level indicator will show the battery level of the lithium battery:

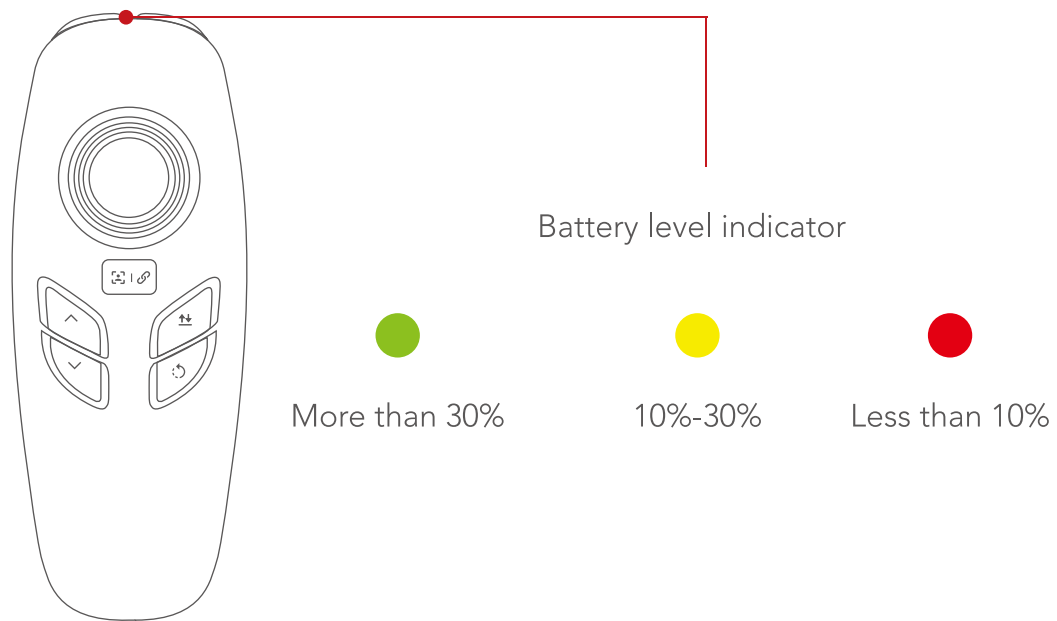

The battery of gesture-based remote controller should be charged with the special charger officially designated by PowerVision, which will not be liable for any consequences caused by charging the battery with the charger not officially provided by PowerVision.

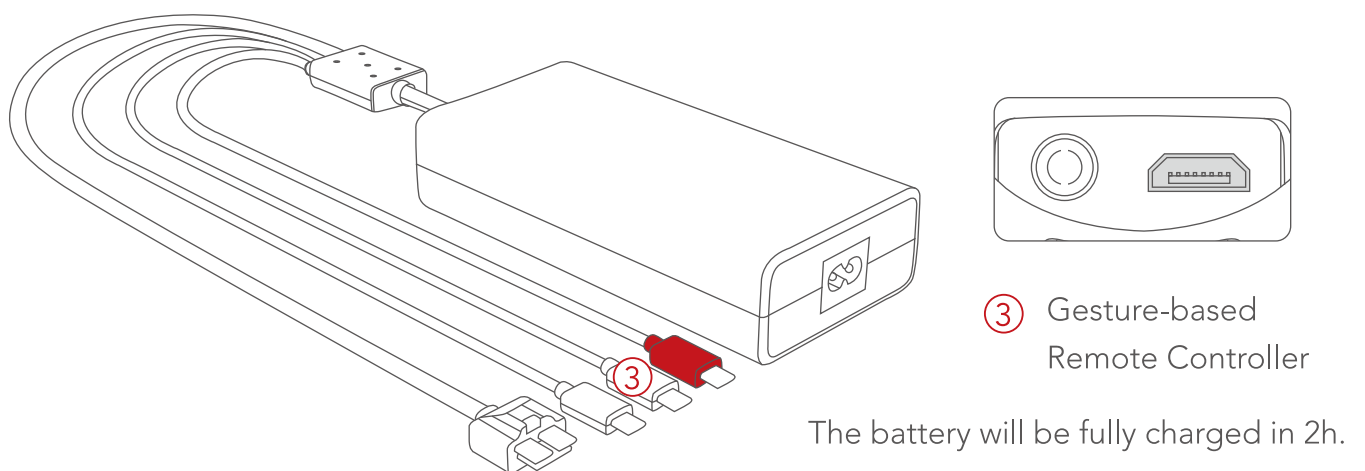

- Control of gesture-based remote controller

Start of motor: short press takeoff key and then keep pressing landing key (complete within 1 second). Then the screw propeller is unlocked and started.

Emergency locking: In case of emergency, press the combination key, i.e. 3-axis gimbal pitch, ascend/descend + taking photos and camera shooting locking propeller, for 2 seconds for emergency shutdown. Such propeller stop mode may be used in case of emergency.

Under normal circumstances, the motor may be automatically stopped when the aircraft lands.

One-click takeoff/landing button: When the aircraft has not taken off, press and hold the key until there is a vibration, and the aircraft begins to take off; when the aircraft takes off, press the key again until there is another vibration, and the aircraft begins to land; short press the key in the process of landing, and the aircraft stops landing.

One-click return-to-home: When the aircraft is not in return-to-home mode, press the key until there is a vibration, and the aircraft begins to return-to-home; when the aircraft is in return-to-home mode, short press the key until there is another vibration, and the aircraft stops return-to-home.

Ascend button: control the upward flight of the aircraft.

Descend button: control the downward flight of the aircraft.

Middle button: short press the button for selfie; keep pressing the key until there is a vibration for the function of following.

Taking Photo/Video shooting button: short press the button for photographing; keep pressing the key until there is a vibration for videoshooting if it is not in video shooting state and for stopping video shooting if it is in camera shooting state.

Joystick: Joystick up and down control 3-axis gimbal pitch; joystick left and right control left-handed rotation/right-handed rotation of the 3-axis gimbal.

Forward and backward/left and right of gesture-based aircraft: Press the gesture activation button, with remote controller positioned pointing straight up, the remote controller can control the forward and backward flight of the aircraft with the bottom as the center point by leaning it forward/backward; the remote controller can control the left and right flight of the aircraft with the bottom as the center point by leaning left/right; when the key is released, the aircraft will hover.

*Gesture-based remote controller is not available to indoor flight, for which standard remote controller shall be used.

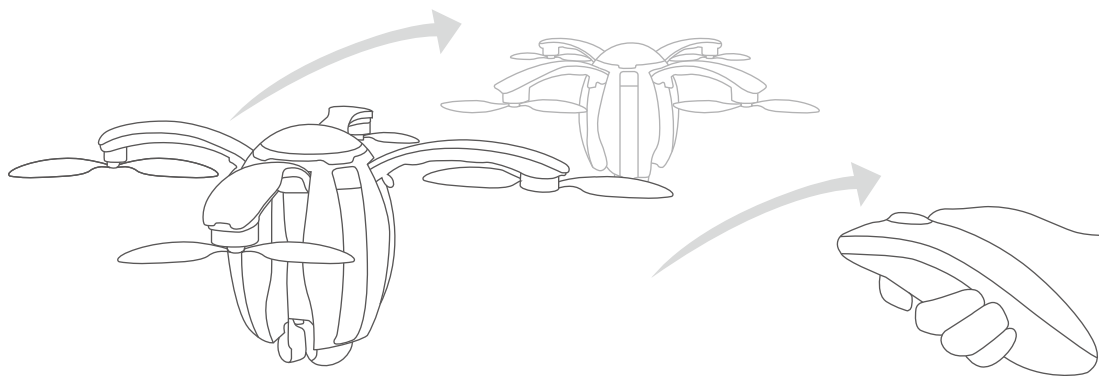

Using the gesture-based control

- Indicator for gesture-based remote controller

The gesture-based remote controller has a three-color battery level indicator. The indicator shows the battery level of the battery when the remote controller is on (whether charging or not): In case of charging when the remote controller is off, the indicator is red, indicating charging; when the remote controller is fully charged, the indicator is green, indicating full charging; in case of emergency alarm during flight, the battery level indicator flashes four times each second in the current color.

- Alarm

Type of Alarm Prompt	Button Backlight	Color of Three-Color Light	Buzzer
Aircraft takeoff/landing prompt	The backlight of takeoff/landing button is normally on.	No action	No action
Aircraft return-to-home prompt	The backlight of return-to-home key is normally on	No action	Dripping sound, 1 cycle for buzz per second
Low power alarm	No action	The red light is normally on	Dripping sound, 4 cycles for buzz per second
Not positioned by GPS	No action	1 cycle per second in the color of current battery level	No action
The aircraft not connected	No action	Cyclic switching of red, green and blue, 3 cycles per second	No action
Change of GPS positioning state	No action	No action	Tick
State change of connection with the aircraft	Inaction	Inaction	Connected, Do-Re-Mi-Fa disconnection, Fa-Mi-Re-Do

Base station

Overview of Base station

This section describes PowerEgg base station, including its usage and precautions. The working frequency band of PowerEgg base station is 2.4Ghz. The base station integrates advanced 4K/HD image transmission system, can directly output HD aerial image to mobile device, and can support mobile phones, tablet computers, and other mobile smart devices with different specifications.

Operation of Base station

- Start-up and shutdown

Press the power switch key for 3 seconds until the indicator near the power key turns on; when it is necessary shut down the base station after use, press the power switch key for 3 seconds again until all indicators are off.

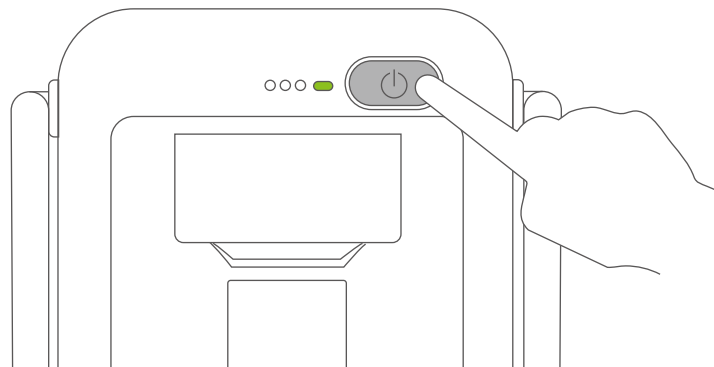

- Connection of wireless base station

For the connection of wireless base station, power on the aircraft and the wireless base station; wait for about 35 seconds, when the 3 Led lights beside the power key are constantly on, the wireless base station is successfully connected to the aircraft. See the figure below:

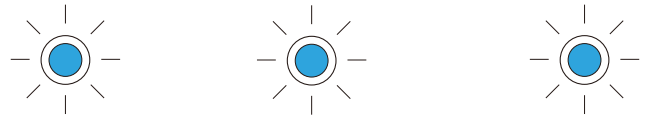
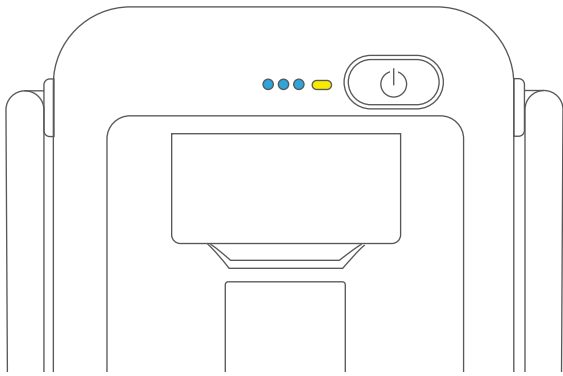

Low ——— Wireless signal ——— High

The number of LED lights indicates the strength of the wireless signal connection.

- Frequency adjustment of base station

Steps:

1. Switch on the aircraft and the base station, and wait for the initialization of the aircraft.
2. Use Vision+ to connect to base station.
3. Press the power key of the aircraft for 10s until the tail status indicator in blue flashes slowly; 3 seconds later, press the power key for 10s until the tail status indicator in blue changes from slow flash to constant light. It enters into frequency adjustment function.

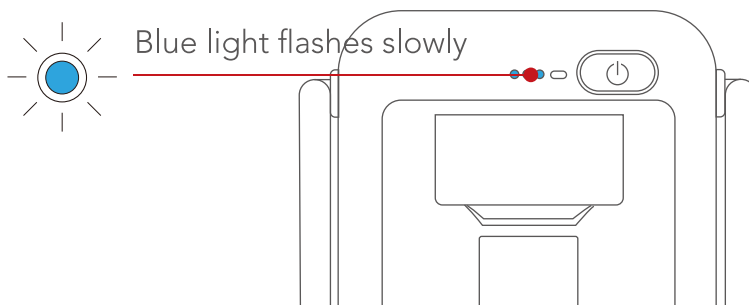
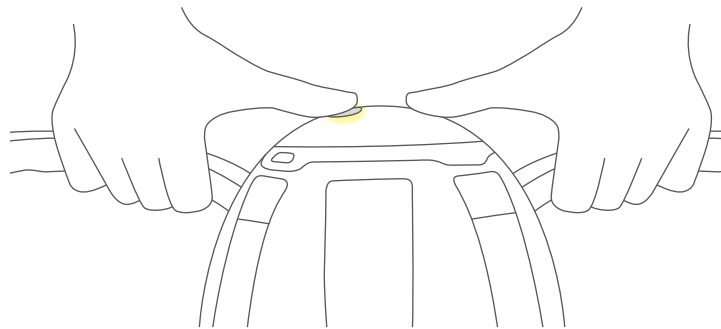

4. Press frequency adjustment key in Vision+ as shown in the following figure:

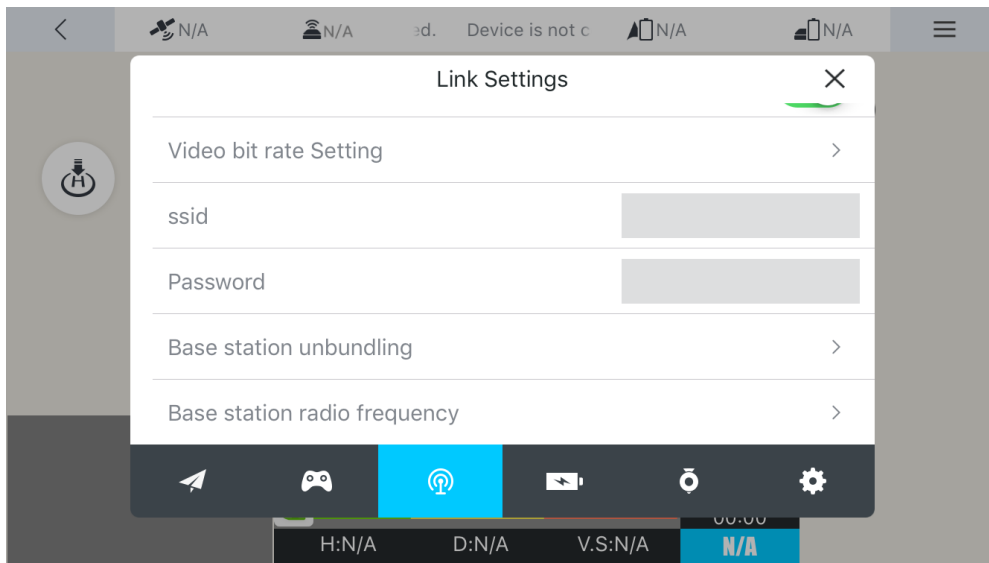

5. When the operation is successful, Vision+ will prompt that frequency adjustment is successfully completed.

- Unbinding

Steps:

1. Switch on the power of aircraft and the power of the base station, and wait the connection between the aircraft and the base station.
2. Use Vision+ to connect to base station.
3. Click the "Unbinding key" of Vision+ to unbind the aircraft and the base station. When the blue LED light of the base station is in water light state, the module is successfully unbound.

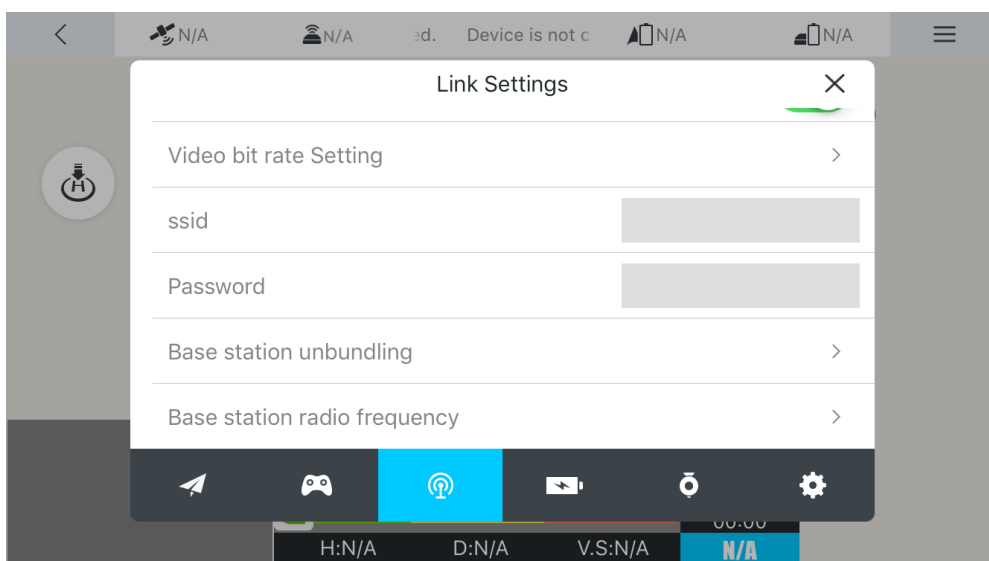

- Charging of base station

The base station should be charged with the special charger supplied by PowerEgg for 5h. The red Micro USB port should be used for charging.

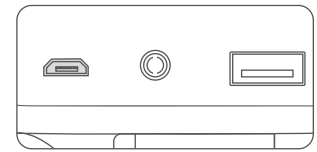
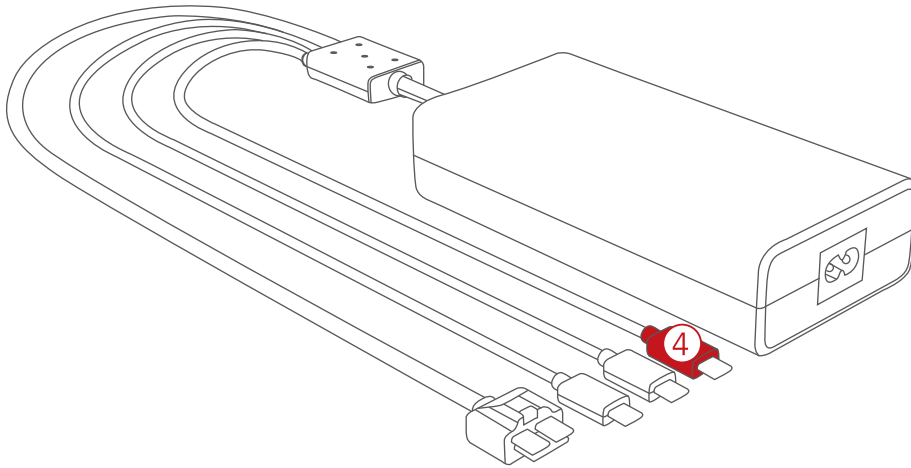

④ Base Station

The module will be fully charged in 5h.

- Indicator of base station

The built-in rechargeable battery of the wireless base station has a capacity of 6,000mAh. The current battery level may be checked via the battery level indicator.

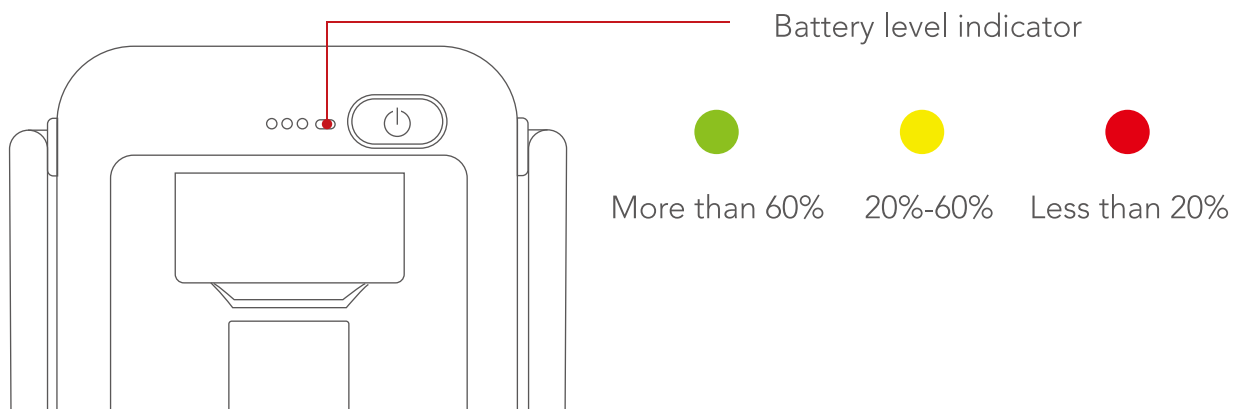

- Compliance version of remote controller

Compliance version: PowerEgg wireless base station complies with both CE standards and FCC standards

4K UHD Gimbal Camera

Overview of 4K UHD Gimbal Camera

This section describes the technical parameters of the camera, and the range of motion and work mode of 4K UHD gimbal camera. Three-axis stabilized gimbal helps the camera isolate the gesture and high-frequency vibration of the aircraft. The control accuracy is up to 0.05° to help the camera take stable and smooth pictures and conduct video shooting. Users can adjust the pitch and heading angle via the finger wheel.

3-axis gimbal use

- Modes

Following mode: the rotation direction of the 3-axis gimbal follows the heading of the aircraft. The pitch and heading are controllable, but rolling is not.

- FPV mode

The motion of the 3-axis gimbal in rolling direction follows the motion of the aircraft in rolling direction. Thus users can obtain the experience of the best flight angle of view.

Precautions:

1. Please open the four arms and bottom cap of the aircraft before switching it on.
2. Please deploy the aircraft landing gear before the landing of the aircraft to avoid impacting the 3-axis gimbal and Camera.
3. Please place the aircraft on flat open ground before taking off and do not impact the gimbal or camera assembly after switching on.

Introduction to Vision+

Overview of Vision+

PV ground control system is the UAV software of PowerEgg. Users can obtain the status information of PowerEgg and can control UAV, 3-axis gimbal and camera module via Vision+.

Download APP and other resuoces

Please scan QD code to download Vision + APP, PC Suite, User Manual, Specification and watch video tutorials.

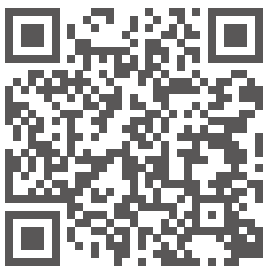

中国区

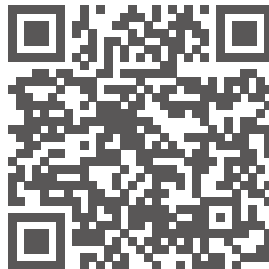

Europe



North America

Product Description

To be used for real-time transmission from the camera, gimbal adjustments, setting of way-points, flight modes, electronic fencing and return-to-home points, and flight logs and the storage of pictures and movies taken, etc.

Introduction to Vision+ Functions

- Homepage



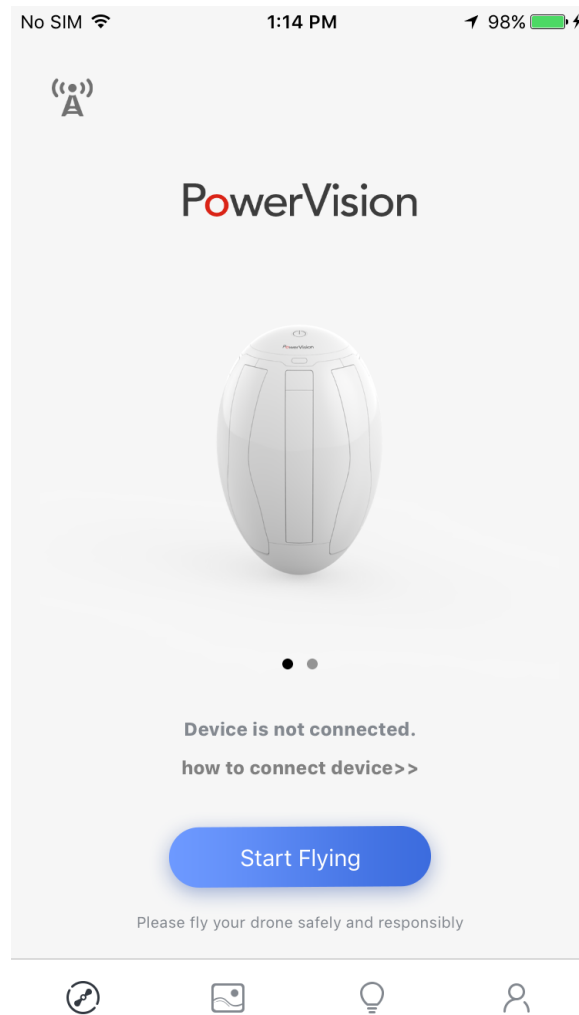



Start Vision+. The interface displays the smart flight page by default; the navigation bar at the bottom displays smart flight, photo album, service and my entrances successively.

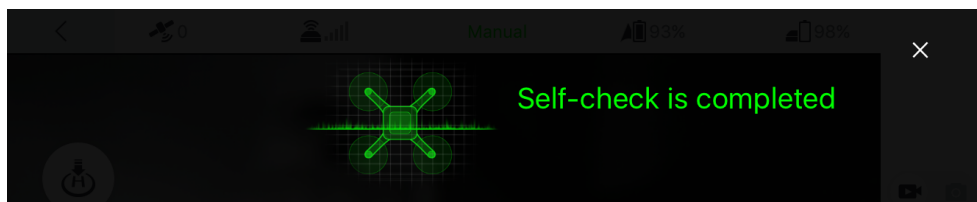

- Systems-Check of the aircraft

When the equipment is connected, click the "Start Flying". A systems check will commence. Flying is only possible after the aircraft passes the systems-check. If something fails the systems-check, it must be resolved prior to flight.



 <p>Sensors> (Normal)</p>	 <p>RC mode (Mode2)</p>	 <p>remote battery (50%)</p>	 <p>aircraft model (Manual)</p>	 <p>battery temp (30°C)</p>
 <p>SD capacity (10.00G)</p>	 <p>Gimbal status (Normal)</p>			

- Display of relevant parameters

Aircraft altitude: it displays N/A if there is no value, and displays the current altitude of the aircraft if there is a value.

Man-machine distance: the distance between the aircraft and the operator.

Vertical velocity: velocity of vertical rise and fall of the aircraft.

Horizontal velocity:the flight velocity of the aircraft at current level.

Flight duration:flight duration for aircraft.

Satellite signal:the number of satellite signals received by the GPS of the aircraft. The aircraft can guide the flight route and trail via satellite signal. Twenty is the maximum number of possible signals received by the GPS of the aircraft.

Base station signal:the strength of signal will impact the efficiency of the aircraft and base station to receive and send information.

Equipment connection status: display of information on connection status of the equipment.

Battery level of the aircraft: it displays N/A if there is no value and displays a percentage (100%) if there is a value.

Battery level of the base station: it displays N/A if there is no value and displays a percentage (100%) if there is a value.

Smart flight menu:waypoint planning, flight mode, return-to-home point setting and safe mode setting.

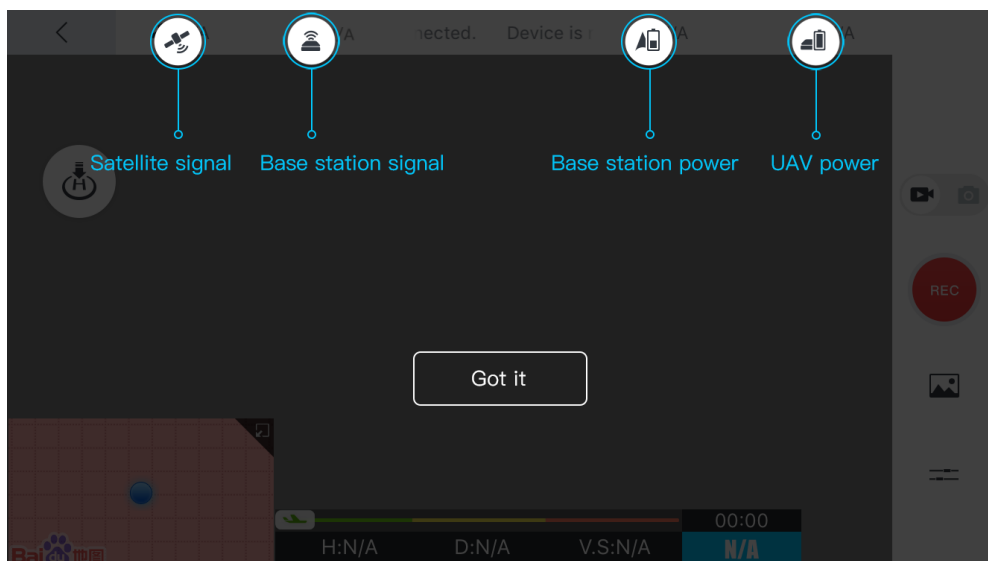

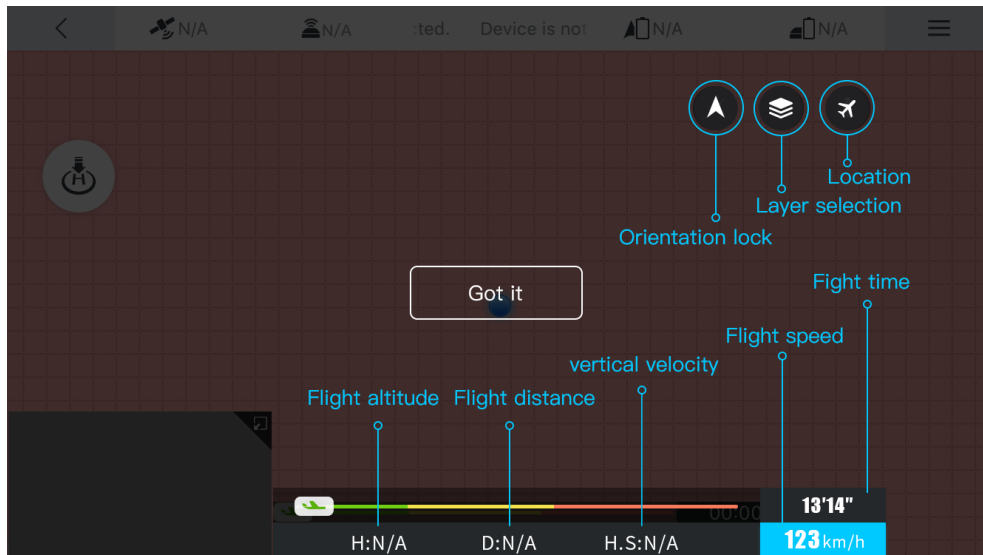

- One-click return-to-home

One-click return-to-home: the aircraft return-to-homes automatically; if "return-to-home point setting" is set, it return-to-homes to the user assigned location; if "return-to-home point setting" is not set, it return-to-homes to the takeoff point. See the "Smart return-to-home" section for details.

- Route planning

Click "waypoint planning" to select the planned points on the map and plan a route by point selection on the map and automatic connection. The velocity, height, hovering duration and other parameters of each waypoint may be set. Upon the completion of planning, click Start, and then the aircraft will automatically execute the flight mission.

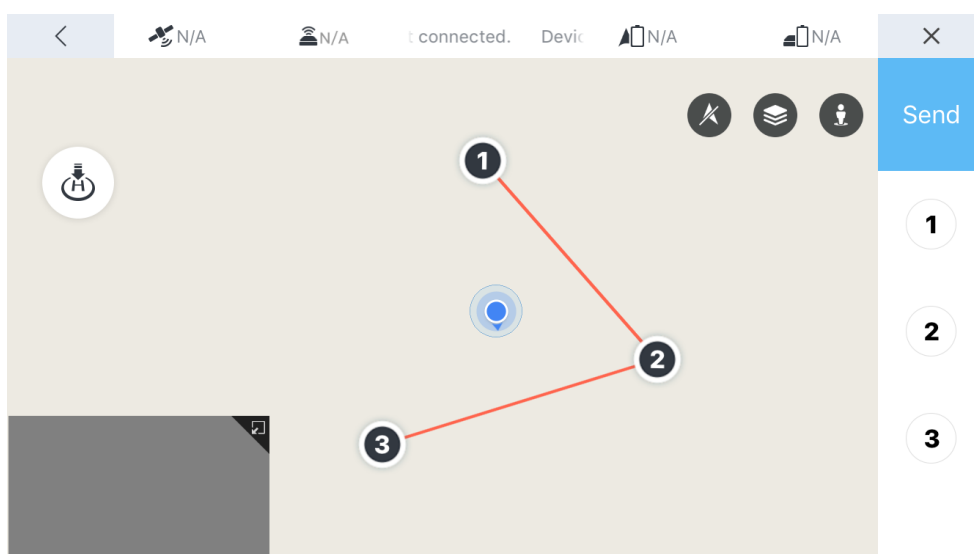

- Flight Mode

Flight modes include circling mode, selfie mode and follow mode.

Orbit mode:The aircraft will orbit a point set by the user in the Vision+ software.

Following mode: when the following mode is started, the aircraft will follow the position of the remote controller at certain distance. Please confirm that the remote controller is started and GPS is normal.

Selfie mode: when selfie mode is started, the aircraft turns about to face the position of the remote controller.

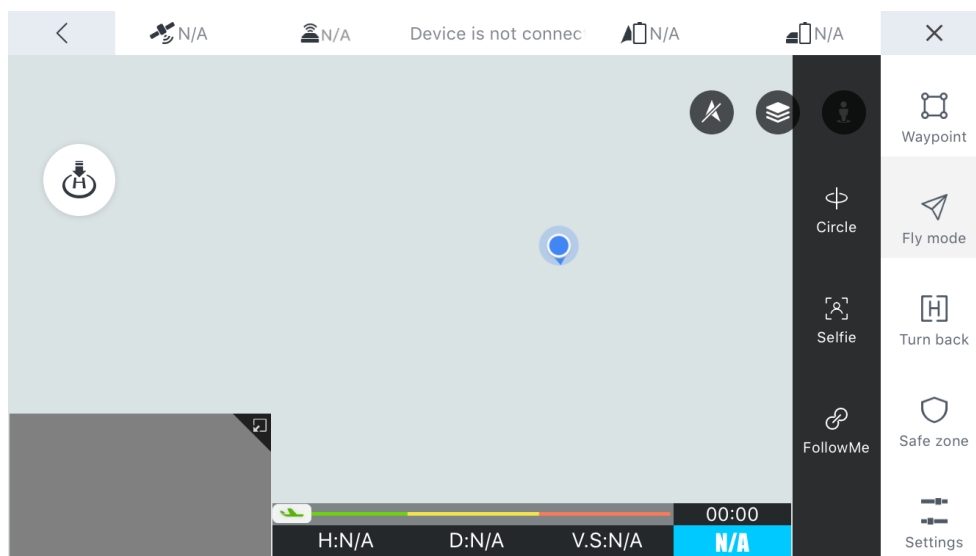

- Return-to-home point setting

Return-to-home point setting includes: current position, aircraft starting point (default value) and point selection on the map.

User position: the aircraft automatically return-to-homes to the current position of the remote controller.

Take-off point of the aircraft:the aircraft automatically return-to-homes to the position of the remote controller.

Location selected on the map: click the map to switch the position of return-to-home point.

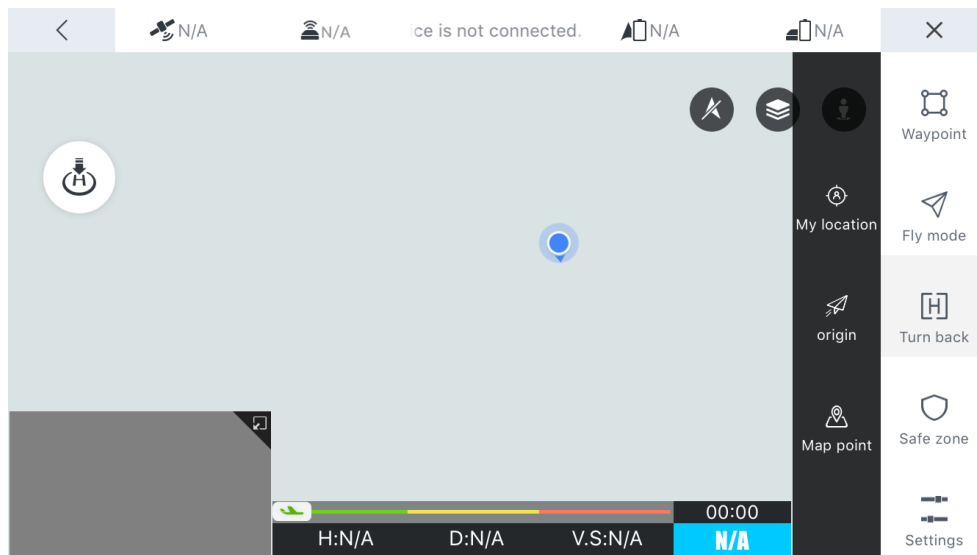

- Electronic fence

Click "safe zone" to select a safe zone on the map. The aircraft will fly within the safe fence in the selected zone. When the aircraft flies outside the electronic fence, it will return-to-home and may stop return-to-home when it enters the electronic fence and keep flying in the original mode.

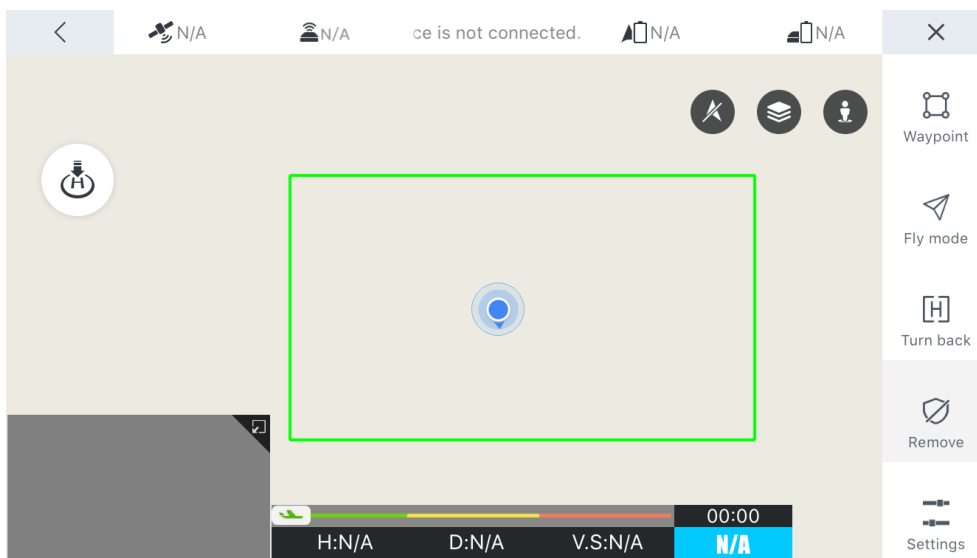

- Positioning

Positioning: human positioning and aircraft positioning.

Not connected to the aircraft: only human positioning is available.

Connected to the aircraft: both the man and the aircraft are positioned.

- Map layer switching

Map mode switching: standard map and satellite map.

- Locking of map orientation

Locking of map orientation:the map orientation is locked by default.

Map locked:the map orientation will not change by rotating the phone left and right.

Map unlocked:the map orientation will change by rotating the phone left and right.

- Back transmission of images

The UAV has a camera image transmission device, which transmits images via RF, data transfer radio or satellite to the base station. The UAV will transmit the real-time pictures to Vision+ and the users can view the flying scene of UAV through Vision+.

- Taking photos and Video Shooting

Shooting module contains: video shooting, image shooting, photo album and camera parameter settings.

Video shooting:control the camera to shoot a video.

Image shooting:control the camera to shoot an image.

Photo album:to cache the videos and images shot by the aircraft in the process of flight (HD original images are stored in SD card of the camera).

Setting of camera parameters:set the resolution, focus mode, flip and other parameters of the camera.

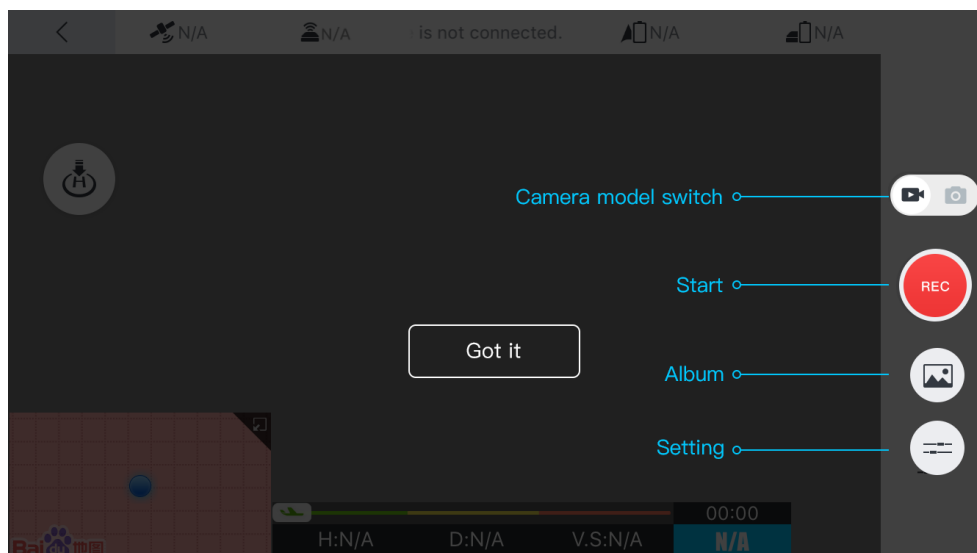

- Setting

Users can configure the flight, remote controller, image transmission, battery, 3-axis gimbal and other options on the map to meet the individual demands of users.

- Flight control setting

Aircraft attitude and compass calibration:when the magnetometer of the aircraft is abnormal, magnetic calibration should be performed manually according to the prompt.

Aircraft landing threshold:users may self-define a minimum battery level for forced landing of the aircraft.

No-fly zone restriction:when no-fly zone restriction is switched on, the aircraft cannot fly in the zone in an unlocked manner.

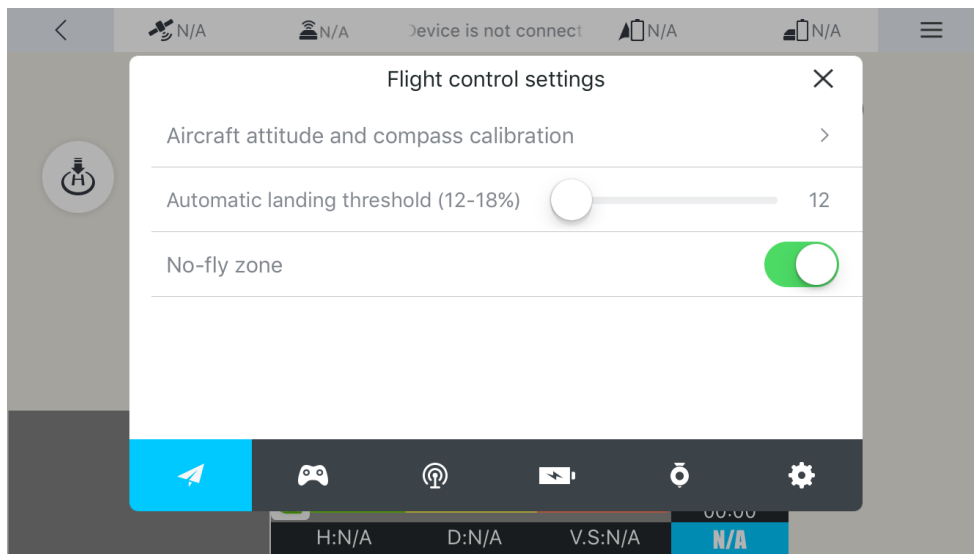

- Remote controller setting

Remote controller calibration: when the remote controller requires calibration, the function may be used to calibrate the remote controller.

Joystick mode: users can select appropriate joystick mode according to their own needs.

EXP: users can self-define EXP according to their own habits.

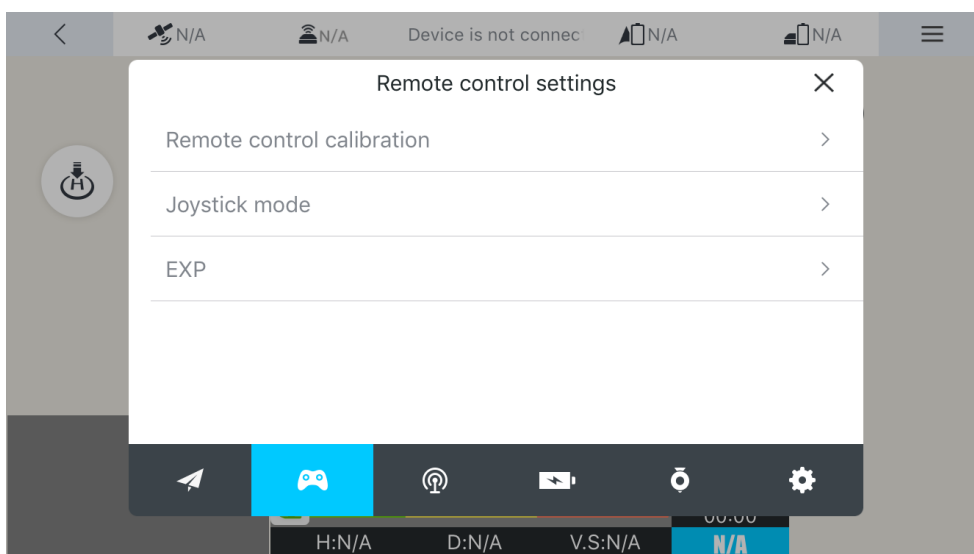

- Link setting

Channel selection: users can select a self-defined channel according to the interference conditions to realize the optimum flight experience.

Automatic setting of the channel: when started, it will automatically select the channel for you without manual setting.

Video code rate setting: users can set the code rate for image transmission according to their own needs.

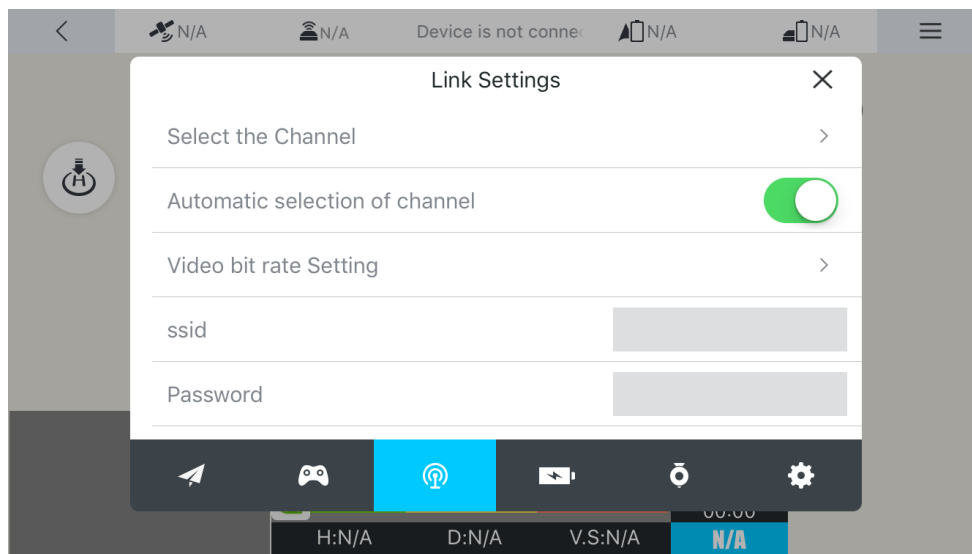

- Battery setting

Voltage display on the main screen: when the switch is switched on, the main screen will display both the current percentage of remaining battery level and voltage. In addition, some details of the aircraft battery can be found here.

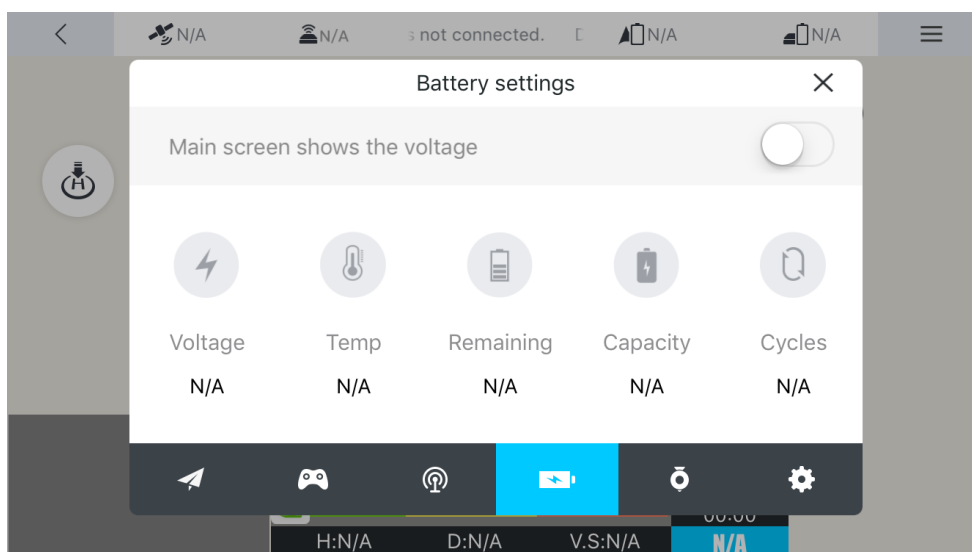

Media Library

It is used to manage photos and videos taken by the aircraft. Here you can upload, download, share, edit and delete pictures and videos.

Service

The Service module includes four sub-modules: Flight Academy, Flight Peripherals, Technical Support, and Repair Application. If you click to enter the corresponding module, it will directly skip to the secondary function page.

■ Flight Academy

Flight Academy allows you to view the videos, messages and other information.

■ Flight Peripherals

Flight Peripherals allow you to view flight messages. Each message page allows third-party sharing and clicking likes.

■ Technical Support

Technical Support is to answer the questions about the UAV, and provide telephone, e-mail and related services.

■ Repair Application

Repair Application is used for the application for after-sales repair services for the UAV.

Flight

Flight Restrictions and Special Restricted Areas

In view of the management system for UAV and airspace control of each country's civil aviation authority, the UAV should not fly in certain specific airspaces to ensure safety. Vision + will prompt the user when the aircraft enters these restricted areas from unrestricted areas, and the user can choose whether to continue the flight. When the aircraft is released to fly from the restricted area, Vision + will prompt the user to choose whether to continue locking and start to fly.

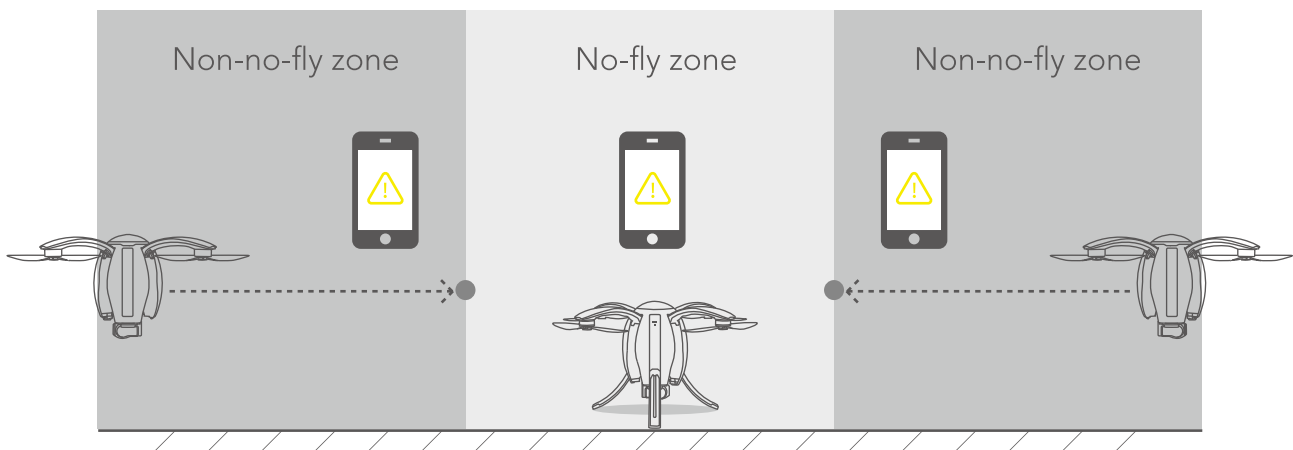

*See the laws of each country for no-fly zones.

Safe Flight Conditions and Precautions

- Flight environment requirements

1. Do not fly in harsh weather, such as windy (wind speed \geq Scale 5), snowy and rainy weather.
2. Beginners are suggested to choose open space for flight; avoid high-voltage cables, towers, communication base stations or transmitting towers and other strong interference facilities, so as not to affect the effective reception of GPS signals and effective communication of remote controller.
3. Please note that flight performance will be affected at high altitude (above 5,000 m above

sea level) due to environmental factors resulting in performance degradation of the battery and power system of the aircraft.

4. GPS mode cannot be used in Antarctic Circle or Arctic Circle, where attitude mode and visual positioning system can be used.

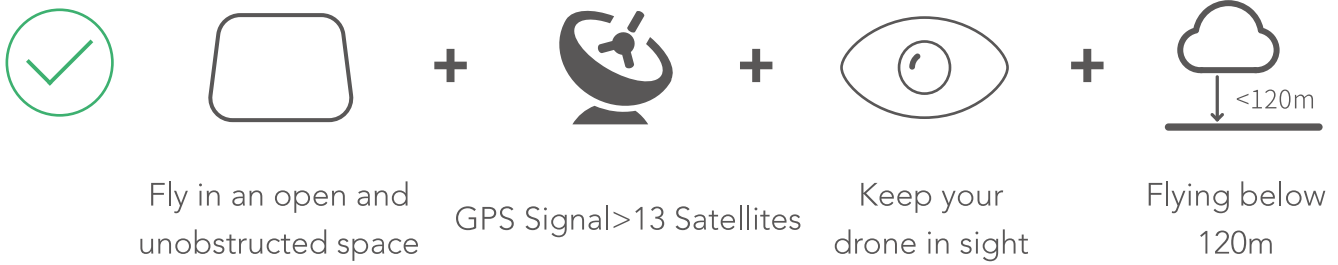

Keep away from crowds, trees, electric wires, tall buildings, airports and signal launching towers. Radio towers, high-voltage wires, substations, and large magnetic metal structures may interfere with its remote controller signals and compasses, threatening flight safety.



Do not fly in severe weather conditions involving rain, smog, snow, tornados and strong wind (speed above 10m/s).

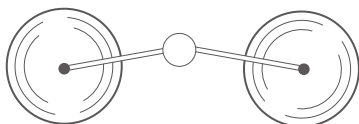

Do not touch the spinning propeller, or it may cause serious personal and property damages.



No-fly zone

Please refer to following website:
<http://knowbeforeyoufly.org/air-space-map/>

Connect the Aircraft, Remote Controller and Vision+

1. Start the standard remote controller / gesture-based remote controller and the base station.

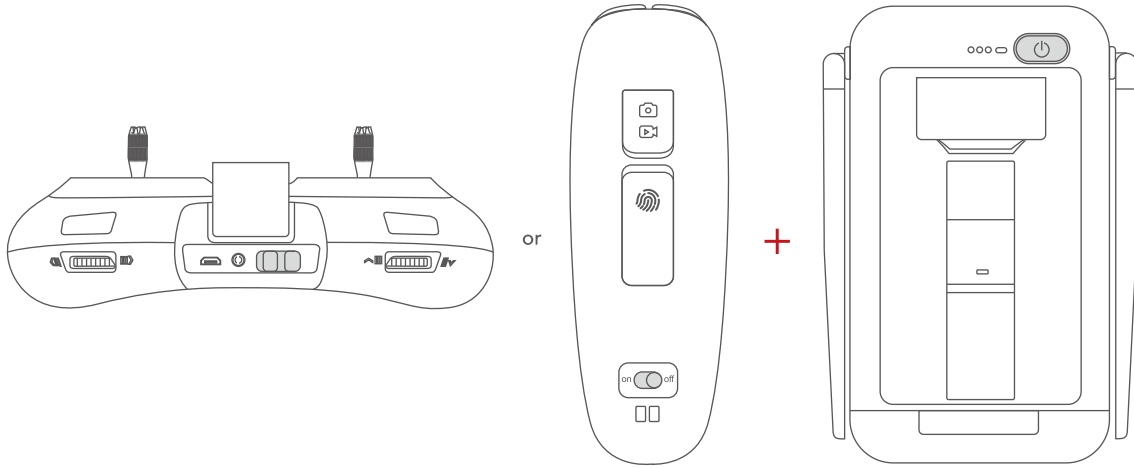

2. Turn on your phone and connect WIFI: Power _ Groundxxx with the password: 1234567890.

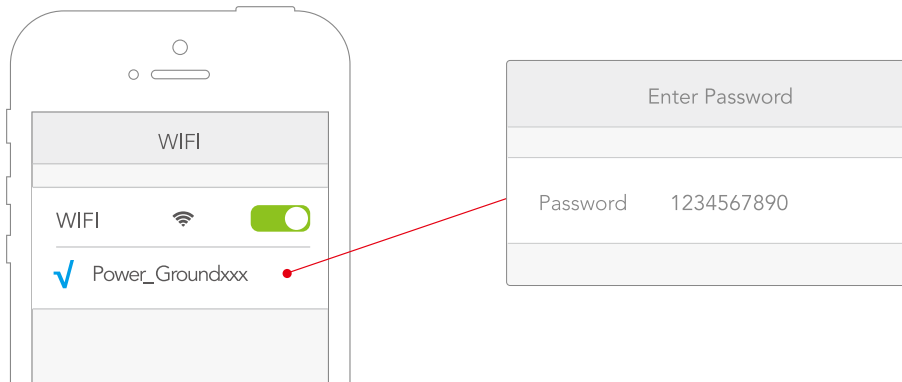

3. Start Vision +. After about 30 seconds, click Start Flying when it shows device is connected.

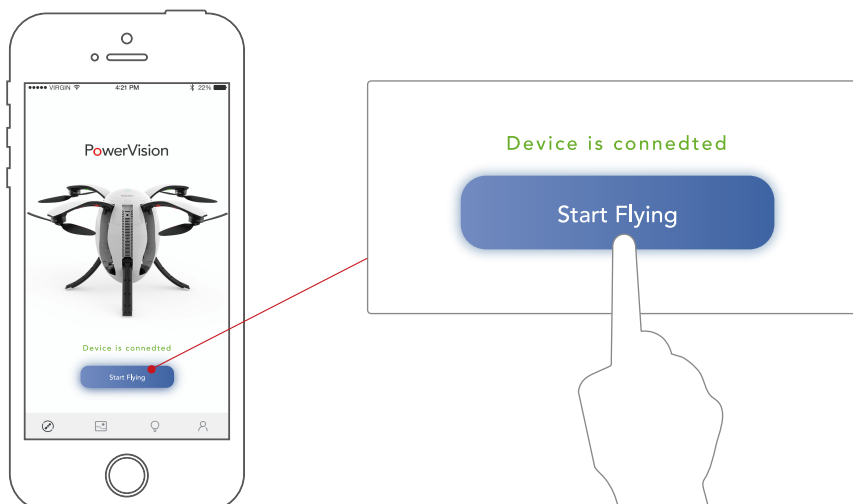

4. For outdoor flight under the mode of P/N/E, wait until aircraft status indicator becomes green, and the status indicator of standard controller or Maestro™ turns green. This indicates the aircraft is prepared for unlocking and flight.

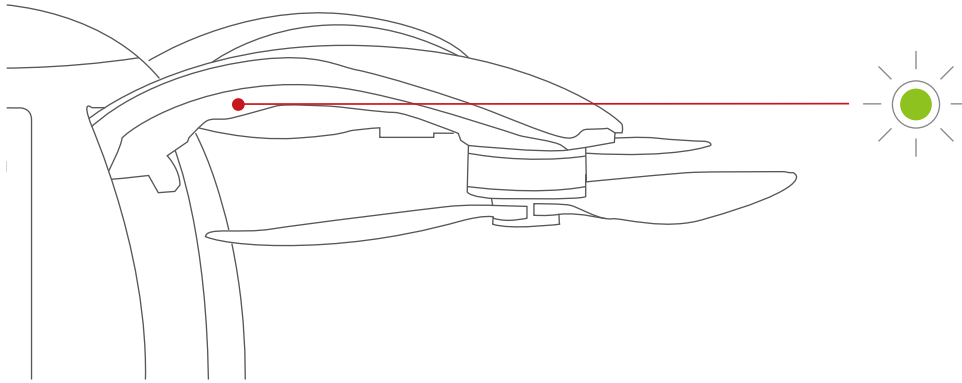

*The Wi-Fi communication frequency of the base station is 5G. Devices not supporting 5G Wi-Fi cannot be connected to the base station. Wi-Fi password can be modified or reset.

**To fly the UAV at unfamiliar locations, please connect the Internet before connecting the base station, and open the APP to zoom in the map to save the data to local cache, so as not to affect the normal display of the map during flight.

5. Press the power button three times in rapid succession, and the landing gear automatically closes. After the propellers are retracted, repeat the process in reverse order to retract the arm. It should be noted that the index finger needs to pull the unlock switch outward, and then follow the momentum to close the arm downward.

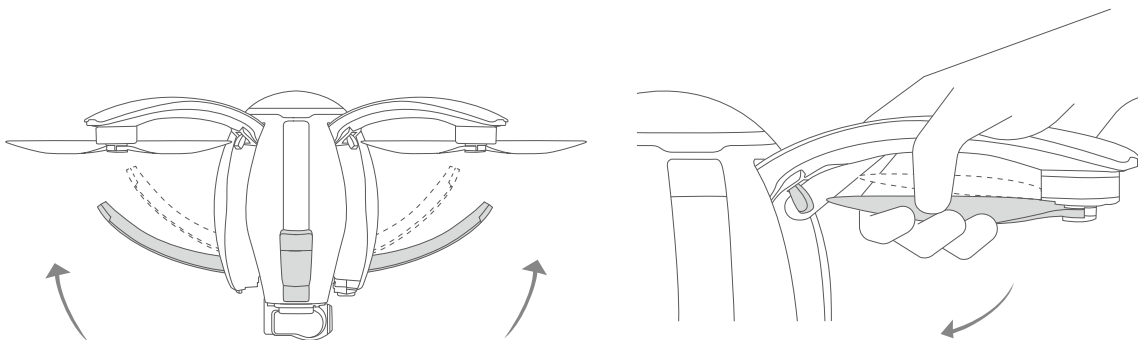

Compass Calibration

- Precautions

The compass must sometimes be calibrated before flight. As the compass is susceptible to the complex environment outside, when calibrating the compass, attention should be paid to the following matters in order to ensure the accuracy of the compass. This is to ensure an ideal condition of the aircraft.

- 1.The calibration site should be open, and away from strong magnetic fields, such as magnetic mines, parking lots, or construction areas with underground steel.
- 2.Do not carry magnetic items, such as mobile phones and keys.
- 3.Do not calibrate the compass indoors.

- Compass calibration procedures

- 1.Open Vision + App. After ensuring the device is connected, enter the "Start to fly" interface, and then click "Setup" in the lower right corner of the menu bar. Then select "Flight Attitude and Compass Calibration" in the flight setup list. Click "Calibration" to enter the "Compass Calibration" interface, and the compass calibration program starts.

- 2.There are six setting positions in the interface, as shown in the figure. Calibration sequence of the three positions is not limited. First, keep it in one position. When the image of the corresponding position of the aircraft becomes yellow, it indicates that the direction has been identified. Then rotate the aircraft around the vertical axis of the current position. When the color of the image turns green, it indicates that the calibration of this direction is completed. Then calibrate the other positions in the same way:

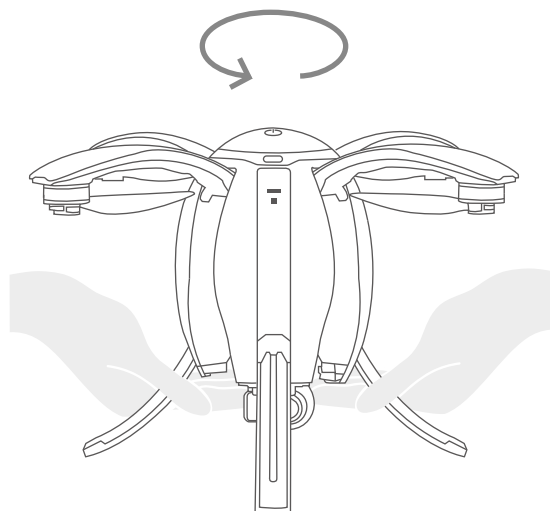

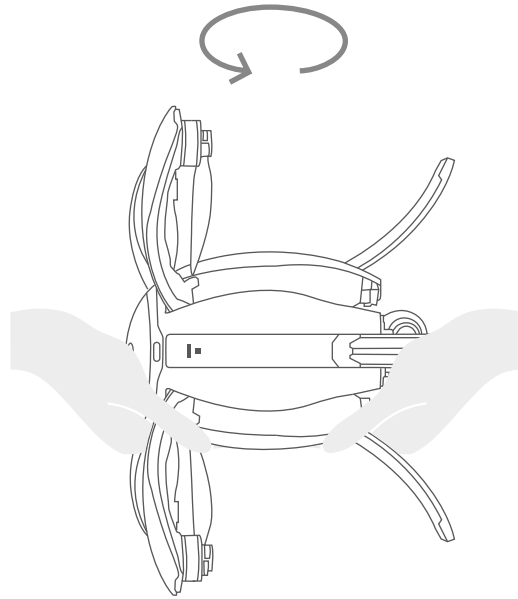

Power button facing forward

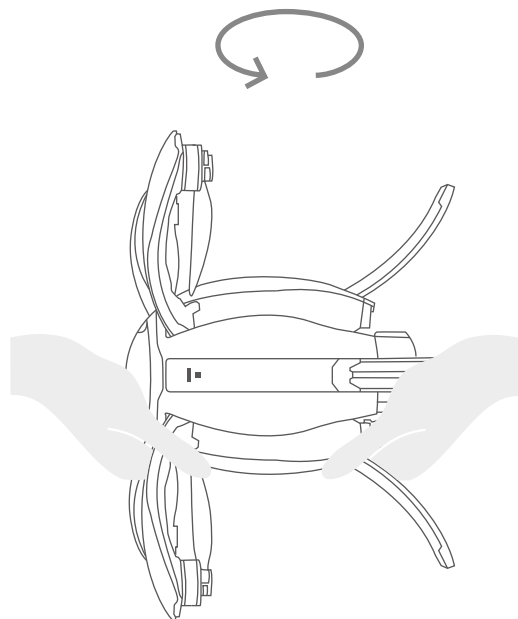

Power button facing upward

3. When the three setting positions in the interface are all green, the calibration is complete.

- Conditions requiring recalibration

1. The flight site is far from the site of last calibration;
2. It spins in flight or cannot fly in a straight line.

Start-up/Shutdown of the Motor

- Start the motor

Connect the remote controller, and pull the sticks down and in to start the motor.

For the **standard remote controller**, pull both joysticks inward and downward to start the motor. After the motor is started, release the joysticks quickly.

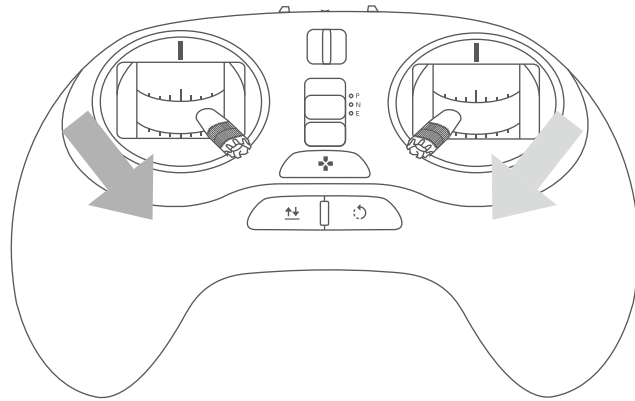

For the **gesture-based remote controller**, press the Ascend key, then press and hold the Descend key to start the motor. After the motor is started, release the key quickly.

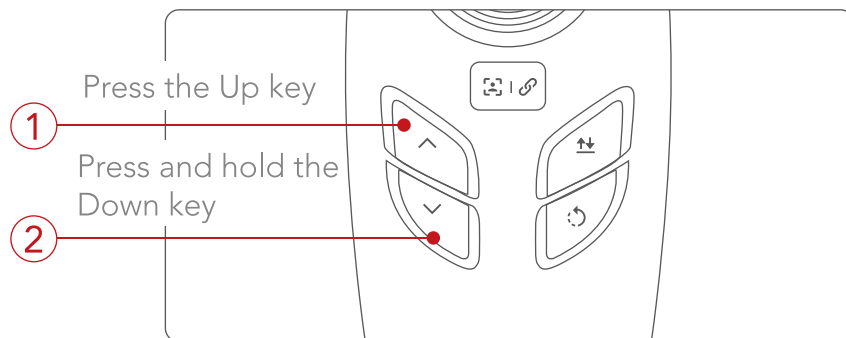

- Shut down the motor

Under normal circumstances, after the aircraft lands on the ground, the user will pull the Ascend/Descend joystick back to the middle or down to the bottom. The aircraft motors will shut down and automatically lock on the ground.

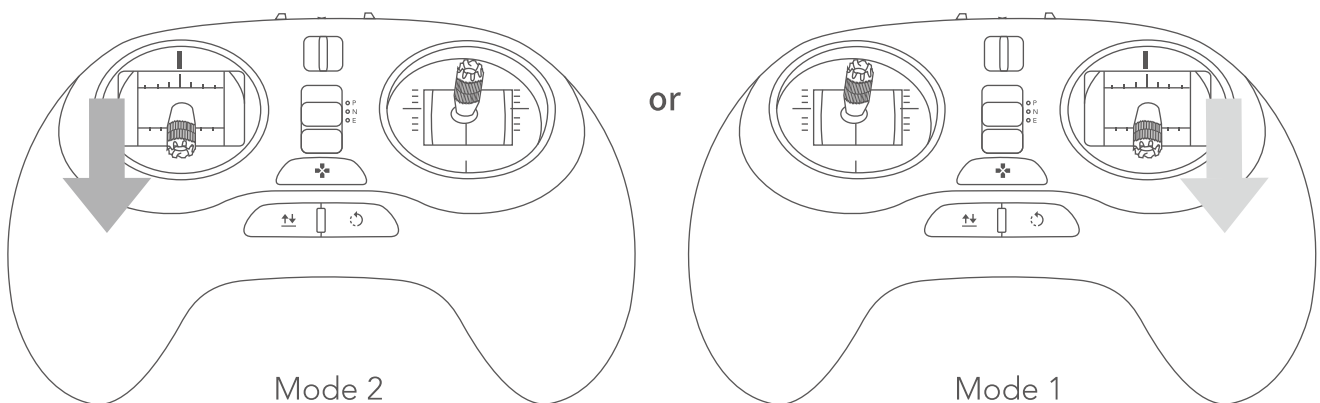

- In-air motor shutdown method

The in-air motor shutdown method can only be used to shut the motor down in case of special conditions (such as when an aircraft is crashing into a crowd) where emergency shutdown is needed to minimize personnel injury. Note: The aircraft will fall to the ground and most likely be destroyed.

Perform the following joystick action to shut the motor down:

Standard remote controller (Mode 1): Pull the Ascend/Descend joystick to the bottom, the yaw joystick to the left, and press and hold the return-to-home button till the remote controller vibrates.

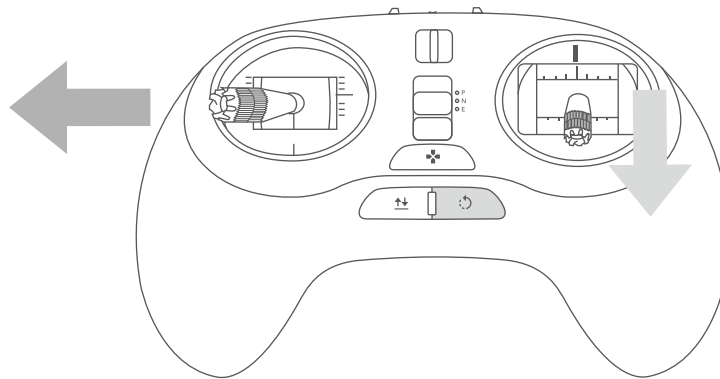

Standard remote controller (Mode 2): Pull the ascend/descend joystick to the lower left corner, and press and hold the return-to-home button till the remote controller vibrates.

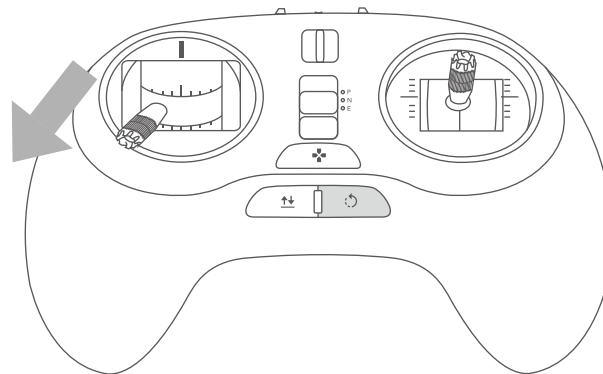

Gesture-based remote controller: Hold down the Descend button+ Camera button and push the joystick to the top till the remote controller vibrates.

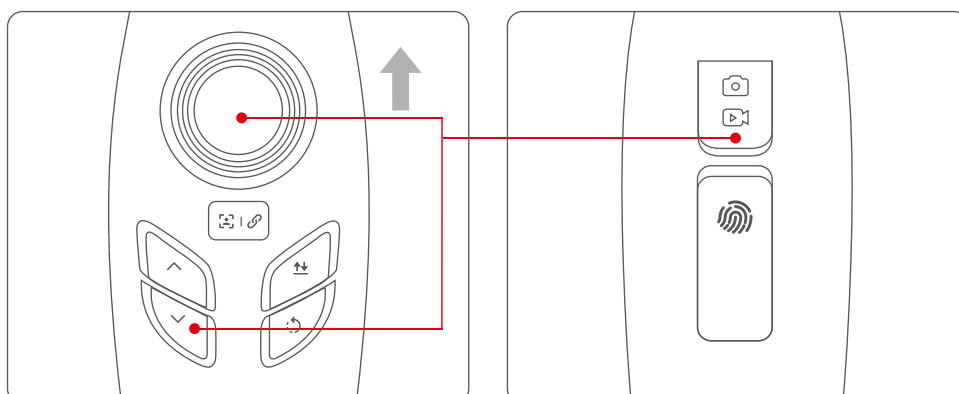

Basic Flight

1. Take out the aircraft, the battery, the base and the remote controller/ base station from the package, and place the aircraft on the base.
 2. Release the buckles at the end of the arms to open the four arms in turn.
 3. Open the aircraft's top cover to place the battery into the body and fasten the cover.
 4. Remove the lower cover (otherwise, it will damage the 3-axis gimbal when it is powered on and initialized).
 5. Press once quickly, then again and hold down the power button to power on the aircraft. Wait for the complete initialization of the aircraft. (LED flashing).
 6. Press the power button three times in quick succession to deploy the landing gear.
 7. Place the aircraft on a flat, open ground surface with the user facing the tail.
 8. Connect the remote controller - Base station – Device.
-

Remote Controller

Standard remote controller – Insert the base station in the support for the standard remote controller. Connect the standard remote controller - base station through a data cable. Fix the Device in the holder on the surface of the base station.

Gesture-based remote controller - Use the data cable to connect the gesture-based remote controller - the base station. Fix the Device in the holder on the surface of the base station. Start with the base station/remote controller. Connect the Device to PowerVision_GroundX WIFI. Open the mobile end Vision +, to enter the initialization state (The remote controller in N mode and E mode without GPS signal will send an alarm. For indoor use, it is recommended to switch the standard remote controller to P mode)

9. Wait for Vision + initialization to complete, and then the APP interface displays "Device connected". Click "Start Flying" to enter the control interface of Vision +, and the APP interface displays the aircraft's status data, flight mode and other information.
10. Wait for the aircraft status indicator to slowly flash yellow or green, which indicates the aircraft is ready.
11. When the Easy mode on the standard remote controller or the gesture-based remote controller is used, GPS positioning is required, and the green indicator of the remote controller is lit on.
12. Use the remote controller to start the motor and keep it idling.
13. When the aircraft's green light slowly flashes, automatic take-off mode can be used.

14. You can also use the remote controller by slowly pushing the Ascend/Descend joystick, to take-off.
15. If descending is needed, slowly pull down the Ascend/Descend joystick, so that the aircraft slowly and steadily lands on the ground.
16. After landing, pull the Ascend/Descend joystick to its lowest position and hold for more than two seconds until the motor is shut down.
17. After shutdown, first turn off the aircraft and then the remote controller.

FCC

This equipment has been tested and found to comply with the limits for a Class B digital device, pursuant to Part 15 of the FCC Rules. These limits are designed to provide reasonable protection against harmful interference in a residential installation. This equipment generates uses and can radiate radio frequency energy and, if not installed and used in accordance with the instructions, may cause harmful interference to radio communications. However, there is no guarantee that interference will not occur in a particular installation. If this equipment does cause harmful interference to radio or television reception, which can be determined by turning the equipment off and on, the user is encouraged to try to correct the interference by one or more of the following measures:

- Reorient or relocate the receiving antenna.
- Increase the separation between the equipment and receiver.
- Connect the equipment into an outlet on a circuit different from that to which the receiver is connected.
- Consult the dealer or an experienced radio/TV technician for help.

Changes or modifications not expressly approved by the party responsible for compliance could void the user's authority to operate the equipment.

This device complies with part 15 of the FCC Rules. Operation is subject to the following two conditions: (1) This device may not cause harmful interference, and (2) this device must accept any interference received, including interference that may cause undesired operation.

The antenna(s) used for this transmitter must be installed to provide a separation distance of at least 20 cm from all persons and must not be co-located or operating in conjunction with any other antenna or transmitter.

This equipment complies with FCC radiation exposure limits set forth for an uncontrolled environment. End user must follow the specific operating instructions for satisfying RF exposure compliance. This transmitter must not be co-located or operating in conjunction with any other antenna or transmitter.

The portable device is designed to meet the requirements for exposure to radio waves established by the Federal Communications Commission (USA). These requirements set a SAR limit of 1.6 W/kg averaged over one gram of tissue. The highest SAR value reported under this standard during product certification for use when properly worn on the body.

IC

This device complies with Industry Canada's licence-exempt RSSs. Operation is subject to the following two conditions:

- (1) This device may not cause interference; and
- (2) This device must accept any interference, including interference that may cause undesired operation of the device.

Cet appareil est conforme aux CNR exempts de licence d'Industrie Canada. Le fonctionnement est soumis aux deux conditions suivantes:

- (1) Ce dispositif ne peut causer des interférences; et
- (2) Cet appareil doit accepter toute interférence, y compris les interférences qui peuvent causer un mauvais fonctionnement de l'appareil.

This equipment complies with ISED radiation exposure limits set forth for an uncontrolled environment. End user must follow the specific operating instructions for satisfying RF exposure compliance. This transmitter must not be co-located or operating in conjunction with any other antenna or transmitter.

The portable device is designed to meet the requirements for exposure to radio waves established by the ISED. These requirements set a SAR limit of 1.6 W/kg averaged over one gram of tissue. The highest SAR value reported under this standard during product certification for use when properly worn on the body.

Cet équipement est conforme aux limites d'exposition aux rayonnements ISED établies pour un environnement non contrôlé. L'utilisateur final doit suivre les instructions spécifiques pour satisfaire les normes. Cet émetteur ne doit pas être co-implanté ou fonctionner en conjonction avec toute autre antenne ou transmetteur.

Le dispositif portatif est conçu pour répondre aux exigences d'exposition aux ondes radio établie par le développement énergétique DURABLE. Ces exigences un SAR limite de 1,6 W/kg en moyenne pour un gramme de tissu. La valeur SAR la plus élevée signalée en vertu de cette norme lors de la certification de produit à utiliser lorsqu'il est correctement porté sur le corps.

PowerVision



Copyright 2017 ©Powervision Robot Inc. All rights reserved.